

République Algérienne Démocratique et Populaire

الجمهورية الجزائرية الديمقراطية الشعبية

Ministère de l'Enseignement Supérieur et de la Recherche Scientifique

وزارة التعليم العالي والبحث العلمي



المدرسة الوطنية المتعددة التقنيات  
Ecole Nationale Polytechnique

Ecole Nationale Polytechnique

Département de Génie Civil

**End-of-study dissertation**

For obtaining the State Engineer's degree in Civil Engineering

**Study of a residential building by considering the effect of  
pounding**

**Realized by:**

Ms MESSILI Nahla

**Supervised by:**

Dr TADJADIT Abdelmadjid

*Defended on June 26, 2024, before a jury composed of:*

President	N.BOURAHLA	Professor	ENP
Supervisor	A.TADJADIT	Associate Professor	ENP
Examiner	A.BOURZAM	Professor	ENP
Guest	R.ZEGHMAR	Doctor	ENP

ENP 2024



République Algérienne Démocratique et Populaire

الجمهورية الجزائرية الديمقراطية الشعبية

Ministère de l'Enseignement Supérieur et de la Recherche Scientifique

وزارة التعليم العالي والبحث العلمي



المدرسة الوطنية المتعددة التقنيات  
Ecole Nationale Polytechnique

Ecole Nationale Polytechnique

Département de Génie Civil

**End-of-study dissertation**

For obtaining the State Engineer's degree in Civil Engineering

**Study of a residential building by considering the effect of  
pounding**

**Realized by:**

Ms MESSILI Nahla

**Supervised by:**

Dr TADJADIT Abdelmadjid

*Defended on June 26, 2024, before a jury composed of:*

President	N.BOURAHLA	Professor	ENP
Supervisor	A.TADJADIT	Associate Professor	ENP
Examiner	A.BOURZAM	Professor	ENP
Guest	R.ZEGHMAR	Doctor	ENP

République Algérienne Démocratique et Populaire

الجمهورية الجزائرية الديمقراطية الشعبية

Ministère de l'Enseignement Supérieur et de la Recherche Scientifique

وزارة التعليم العالي والبحث العلمي



المدرسة الوطنية المتعددة التقنيات  
Ecole Nationale Polytechnique

Ecole Nationale Polytechnique

Département de Génie Civil

### Mémoire de fin d'étude

Pour l'obtention du diplôme d'Ingénieur d'Etat en Génie Civil

## Étude d'un bâtiment à usage d'habitation avec prise en compte du phénomène d'entrechoquement

**Réalisé par :**

Mlle MESSILI Nahla

**Encadré par :**

Dr TADJADIT Abdelmajid

*Soutenu le 26 Juin 2024, Devant le jury composé de :*

Président	N.BOURAHLA	Professeur	ENP
Promoteur	A.TADJADIT	MCB	ENP
Examineur	A.BOURZAM	Professeur	ENP
Invitée	R.ZEGHMAR	Docteur	ENP

ENP 2024

## ملخص

الجزائر منطقة زلزالية شديدة الخطورة. تضع لوائح البناء قواعد للتصميم والحساب في المناطق الزلزالية من أجل تقليل المخاطر والأضرار في حالة حدوث حركة أرضية قوية أو معتدلة. استُخدمت هذه القواعد لإجراء دراسة تفصيلية لمبنى من الخرسانة المسلحة للاستخدام السكني، يتكون من طابق أرضي وخمسة طوابق، ويقع في خميس الخشنة. يهدف المشروع إلى تحديد أبعاد المبنى والتحقق من ثباته. بالإضافة إلى ذلك، تفحص الدراسة نتائج طرق المباني المتجاورة والمعايير المختلفة التي تؤثر على هذه الظاهرة.

**الكلمات المفتاحية:** هيكل -خرسانة مسلحة -الطرق الزلزالي -المباني المتجاورة

## Résumé

L'Algérie est une zone à haut risque sismique. Les règles de construction établissent des règles de conception et de calcul dans les zones sismiques afin de minimiser les risques et les dommages lors d'un mouvement de terrain fort ou modéré. Ces règles ont été utilisées pour réaliser une étude détaillée d'un bâtiment en béton armé à usage résidentiel, avec un rez-de-chaussée et cinq étages, situé à Khemis El Khchena. Le projet vise à dimensionner et à vérifier la stabilité du bâtiment en tenant compte des recommandations de BAEL91 modifié 99 et CBA93 ainsi celle du RPA99/2003. En outre, l'étude examine les résultats du martèlement des bâtiments adjacents et les différents paramètres qui influencent ce phénomène.

**Mots clés :** structure - béton armé - martèlement sismique - bâtiments adjacents

## Abstract

Algeria is a high seismic risk zone. The construction regulations establish design and calculation rules in seismic zones to minimize risks and damage during strong or moderate ground motion. These regulations were used to carry out a detailed study of reinforced concrete building for residential use, composed of ground plus five storeys, located in Khemis El Khchena. The project aim to calculate the different bearing elements of this building and verify it's global stability while considering the recommendations of BAEL91 modified in 99 and CBA93 as well as RPA99ver.2003. Additionally, the study investigate the results of the pounding of adjacent buildings and the various parameters influencing this phenomenon.

**Key words:** structure - reinforced concrete – seismic pounding – adjacent buildings

# Dedication

*I dedicate this thesis to,*

*My dear parents, Mr. Messili Mourad and Mme. Messili Rebiha*

*This dedication cannot fully express my gratitude towards your support, encouragement and sacrifices. Your belief in me has been my source of motivation and pushed me to reach this stage.*

*My sisters, Asma and hadjer, and my brother Lamine*

*Thank you for your constant support and words of encouragement.*

*To my dear friends, Sana, Nasrine, Zina, Khawla.*

*Your companionship and support have made my academic journey enjoyable.*

*To my friends Soumia, Chems Eddine and all those who have supported me throughout this journey.*

*To myself.*

*Thank you.*

# Acknowledgments

Praise be to ALLAH alone, merciful and gracious,

First, I would like to express my sincere thanks to my supervisor,  
Dr. Tadjadit Abdelmadjid, for his wise advices, his availability throughout  
this journey, and his encouragements which enabled me to successfully  
complete this end-of-study project.

My sincere thanks then go to Mrs. Taouinet Zahia, for her support  
and for providing the necessary resources for this project and  
to the whole team of the office of study of the habitat of  
Algiers for their welcome and assistance.

I would like to express my sincere thanks to my teachers  
as well as the members of the jury Pr. Bourahla Nouredine and  
Pr. Bourzam Abdelkrim, who have done me the honor of  
evaluating this work

To all those who have contributed in any way to the realisation  
of this project, please find here a testimony of my thanks.

# Contents

List of tables

List of figures

List of abbreviations

Introduction.....	15
I Chapter: Presentation of the project.....	17
I.1 Introduction .....	17
I.2 Description of the project .....	17
I.2.1 Location of the project .....	17
I.2.2 Geometrical characteristics .....	17
I.3 Site investigation .....	20
I.4 Characteristics derived from reconnaissance campaigns .....	20
I.5 Hydrogeological context.....	21
I.6 Mechanical properties of materials.....	21
I.6.1 Concrete .....	21
I.6.2 Steel.....	23
I.7 Actions to be taken into account.....	25
I.8 Load combinations .....	25
I.9 Used Regulations.....	26
I.10 Conclusion.....	26
II Chapter: Preliminary sizing of structural elements .....	28
II.1 Introduction .....	28
II.2 Preliminary sizing of floors .....	28
II.2.1 Hollow-core slab .....	28
II.2.2 Reinforced concrete solid slab .....	28
II.3 Load evaluation .....	30
II.4 Stairs .....	32
II.4.1 Stairs terminology .....	32
II.4.2 Dimensions.....	33



II.4.3	Evaluation of permanent loads and overloads of stairs.....	34
II.5	Preliminary sizing of the parapet.....	35
II.6	Preliminary sizing of beams .....	36
II.7	Shear wall Preliminary sizing.....	37
II.8	Preliminary sizing of columns .....	38
II.9	Conclusion.....	46
III	Chapter: Study of secondary elements .....	48
III.1	Introduction.....	48
III.2	Floor study .....	48
III.2.1	Hollow core slab.....	48
III.2.2	Solid slab floor .....	55
III.3	Study of the parapet .....	60
III.4	Study of stairs .....	63
III.4.1	Study of the flight I .....	64
III.5	Conclusion .....	68
IV	Chapter: Dynamic study.....	70
IV.1	Introduction.....	70
IV.2	Objective of the dynamic study .....	70
IV.3	Mathematical modelling .....	70
IV.4	Presentation of the ETABS software .....	70
IV.5	Choice of the calculation method .....	71
IV.6	Modal spectral analysis method.....	71
IV.6.1	Principle .....	71
IV.6.2	Response spectrum.....	71
IV.7	Dynamic analysis .....	73
IV.7.1	Structural modeling .....	73
IV.7.2	Modelling steps .....	73
IV.7.3	Vibration periods and mass participation.....	75
IV.7.4	Calculation of the total seismic force.....	76
IV.7.5	Calculations Verification.....	78
IV.7.6	Justification of the results.....	79
IV.8	Conclusion .....	83
V	Chapter: Reinforcement of structural elements.....	86
V.1	Introduction : .....	86
V.2	Study of beams .....	86
V.2.1	Calculation of reinforcement.....	87

V.2.2	Service limit state verification.....	90
V.2.3	Reinforcement details.....	93
V.3	Study of columns.....	94
V.3.1	Calculation of reinforcement.....	95
V.3.2	Reinforcement details.....	99
V.4	Study of shear walls.....	99
V.4.1	Shear wall arrangement and characteristics .....	100
V.4.2	Reinforcement calculations .....	101
V.4.3	Reinforcement details.....	107
V.5	Conclusion.....	107
VI	Chapter: Study of the Infrastructure.....	109
VI.1	Introduction.....	109
VI.2	Choice of foundations type .....	109
VI.3	Study of strip footing .....	111
VI.3.1	Dimensioning of the crossed strip footings.....	111
VI.3.2	Verification of overturning stability.....	113
VI.3.3	Footing reinforcement .....	114
VI.3.4	Study of the rib.....	117
VI.4	Conclusion .....	122
VII	Chapter: Analysis of Buildings Pounding.....	124
VII.1	Introduction.....	124
VII.2	Causes of pounding.....	125
VII.3	Dimensions of the seismic joint.....	125
VII.4	Methodology.....	126
VII.4.1	Brief description of study buildings .....	126
VII.4.2	Different models of pounding.....	129
VII.4.3	Properties of gap element .....	130
VII.4.4	Seismic loads .....	131
VII.5	Results and discussion .....	132
VII.6	Mitigation of pounding .....	143
VII.7	Conclusion .....	143
	Conclusion.....	144
	Bibliography.....	146
	Appendices.....	148

# List of tables

Table I-1: Admissible ground stress and anchoring height.....	21
Table II-1: Evaluation of typical floor loads.....	30
Table II-2: Evaluation of balcony loads.....	30
Table II-3: Evaluation of terrace floor loads.....	31
Table II-4: Evaluation of reinforced concrete wall loads.....	31
Table II-5: Evaluation of wall load.....	31
Table II-6: Evaluation of operating loads.....	32
Table II-7: Loads and overloads evaluation for landing.....	34
Table II-8: Loads and overloads evaluation for steps.....	35
Table II-9: Dimensions of principal and secondary beams.....	37
Table II-10: Law of degression of operating loads.....	40
Table II-11: Surface area and weight of the typical floor and terrace tributary to the most loaded central column.....	41
Table II-12: Volume and weight of the principal and secondary beams supported by the most loaded central column.....	41
Table II-13: Normal effort due to the load distribution.....	42
Table II-14: Surface area and weight of the typical floor and terrace tributary to the most loaded boundary column.....	43
Table II-15: Volume and weight of the principal and secondary beams supported by the most loaded boundary column.....	43
Table II-16: Normal effort due to the load distribution.....	43
Table II-17: Surface area and weight of the typical floor and terrace tributary to the most loaded corner column.....	44
Table II-18 : Volume and weight of the principal and secondary beams supported by the most loaded corner column.....	45
Table II-19: Normal effort due to the load distribution.....	45
Table II-20: Preliminary sizing of elements.....	46
Table III-1: Results of longitudinal reinforcement in spans.....	54
Table III-2: Results of longitudinal reinforcement at supports.....	54
Table III-3: Verification of shear stress.....	54
Table III-4: Results of moments calculations.....	57
Table III-5: Loads evaluation.....	61
Table III-6: Combination of action on the stairs.....	64
Table IV-1: Values of each factor.....	72
Table IV-2: Vibration periods and the mass participation rate.....	75
Table IV-3: The verifications of the resultant of the seismic forces in both directions.....	79

Table IV-4: Results of the verification of the reduced normal force .....	79
Table IV-5: Verification of relative displacement along x .....	80
Table IV-6: Verification of relative displacement along y .....	80
Table IV-7: The Value of $M_s$ and $M_r$ in x direction .....	81
Table IV-8: The Value of $M_s$ and $M_r$ in y direction .....	82
Table IV-9: Verification of P-delta effect in x and y directions .....	83
Table V-1: Reinforcements sections for principal beams .....	88
Table V-2 : Reinforcements sections for secondary beams linked to shear walls .....	89
Table V-3: Reinforcements sections for secondary beams .....	89
Table V-4: Reinforcements sections for tie beams .....	89
Table V-5: Verification of the stresses.....	90
Table V-6: Shear stress verification for beams .....	91
Table V-7: Transversal reinforcements sections .....	92
Table V-8: Reinforcement Section for Columns (45×45) cm <sup>2</sup> .....	95
Table V-9: Reinforcement Section for Columns (40×40) cm <sup>2</sup> .....	96
Table V-10: Transversal reinforcements sections for columns.....	97
Table V-11: Transversal reinforcement section according to RPA99/2003 .....	98
Table V-12: Shear stress verification for columns .....	98
Table V-13: Dimension of the shear walls .....	100
Table V-14: Design stresses for wall 9 .....	102
Table V-15: Results of stresses of shear walls .....	105
Table V-16: Results of reinforcement of shear walls on all levels .....	106
Table V-17: Results of shear stress verification.....	107
Table VI-1: The SLS verification in transversal direction .....	112
Table VI-2: The SLS verification in longitudinal direction .....	113
Table VI-3: Overturn verification in transversal and longitudinal directions .....	114
Table VI-4: Main and distribution reinforcement in transversal direction .....	116
Table VI-5: Main and distribution reinforcement in longitudinal direction .....	117
Table VI-6: Reinforcement of the rib beam in both directions .....	120
Table VI-7: Verification of the stress in both directions.....	121
Table VI-8: Verification of the shear stress for the rib .....	122
Table VII-1: The Fundamental periods with the modal mass participation.....	133
Table VII-2: The Displacements of the two nodes with and without pounding .....	133
Table VII-3: The Fundamental periods with the modal mass participation.....	136
Table VII-4: The Displacements of the two nodes with and without pounding .....	136
Table VII-5: The Fundamental periods with the modal mass participation.....	140
Table VII-6: The Displacements of the two nodes with and without pounding .....	140

# List of Figures

Figure I-1: Satellite photo .....	17
Figure I-2: Architectural plan of the ground floor .....	18
Figure I-3: Standard floor architectural plan.....	19
Figure I-4: Concrete Stress- Deformation Diagram.....	22
Figure I-5: Stress-Deformation Diagram for Steel.....	24
Figure II-1: Section of a stair, with its components .....	32
Figure II-2: Section of shear wall in plan.....	38
Figure II-3:Reduced column cross-section .....	38
Figure II-4: Floor area tributary to the most loaded central column.....	41
Figure II-5: Floor area tributary to the most loaded Boundary column.....	42
Figure II-6: Floor area tributary to the most loaded corner column.....	44
Figure II-7: Formwork of columns.....	46
Figure III-1: Diagram of beam span.....	48
Figure III-2: The flat-rate coefficient for the calculation of moment .....	51
Figure III-3 : Cross-section of a joist .....	52
Figure III-4: Reinforcement details of joists .....	55
Figure III-5: Three-sided embedded panel.....	56
Figure III-6: Reinforcement details of the Balcony .....	60
Figure III-7: Static model of flight I.....	64
Figure III-8: Diagram of forces applied to staircases at ULU.....	64
Figure III-9: Reinforcement details of flight I .....	68
Figure IV-1: Spectral response.....	73
Figure IV-2: Structural modeling .....	74
Figure IV-3: Mode shapes.....	76
Figure V-1: Reinforcement details for principal beam .....	93
Figure V-2: Reinforcement details for secondary beam .....	94
Figure V-3: Reinforcement details for tie beam.....	94
Figure V-4: Reinforcement details for columns.....	99
Figure V-5: Dimension of the shear walls .....	100
Figure V-6 : Arrangement of Vertical Reinforcement in Walls.....	103
Figure V-7: Reinforcement details for shear wall V9 .....	107
Figure VI-1: Diagram of an isolated footing.....	110
Figure VI-2: Dimension of the footing .....	112
Figure VI-3: Reinforcement diagram for the strip footing 1.....	116
Figure VI-4: Diagram of efforts in the rib in the x direction .....	119
Figure VI-5: Diagram of efforts in the rib in the y direction .....	119
Figure VI-6: Reinforcement diagram of the rib .....	122
Figure VII-1: Examples of structural damage caused by pounding.....	124
Figure VII-2: Pounding categorization[7].....	125
Figure VII-3: Minimum width of the seismic joint in accordance with RPA99/2003.....	126

Figure VII-4: Building model 1 .....	127
Figure VII-5: Building model 2 .....	128
Figure VII-6: Building model 3 .....	128
Figure VII-7 : Different models of pounding.....	129
Figure VII-8 : Gap element .....	130
Figure VII-9 : Modelling of gaps .....	131
Figure VII-10: Time history plot of El-centro earthquake .....	132
Figure VII-11: Time displacements graph of nodes without pounding .....	134
Figure VII-12: Time displacements graph of nodes with pounding .....	134
Figure VII-13: Pounding force for gap 0 mm .....	135
Figure VII-14: Time displacements graph of Nodes without Pounding .....	136
Figure VII-15: Time displacements graph of Nodes with Pounding .....	137
Figure VII-16: Distribution of Maximum Pounding Force on various Floors.....	137
Figure VII-17: Pounding force for with gap distances 0 mm and 30mm .....	138
Figure VII-18: Velocity graph for node 2 with gap distances 0 mm and 30mm .....	139
Figure VII-19: Velocity graph for node 1 with gap distances 0 mm and 30mm .....	139
Figure VII-20: Time displacements graph of nodes without pounding .....	141
Figure VII-21: Time displacements graph of nodes with pounding .....	141
Figure VII-22: Distribution of maximum pounding force on various floors .....	142
Figure VII-23: Pounding force for gap 0 and 30mm .....	142

# List of Abbreviations

<b>ULS</b>	Ultimate limit state
<b>SLS</b>	Service limit state
<b>R.B</b>	Re- bar
<b>D.B</b>	Deformed bar
<b>W.M</b>	Welded wire mesh
<b>GF</b>	Ground floor
<b>SF</b>	Strip foundation ( Strip footing)

# **Introduction**



Earthquakes, due to their unpredictable nature and the damage they cause to buildings, require structures to be designed to withstand the dynamic forces they induce, in addition to the static loads they support. Among the damage observed after moderate to violent earthquakes is that caused by the pounding of structures, which occurs when the separation between adjacent structures is insufficient, potentially leading to severe damage or even collapse.

The objective of the thesis is to carry out the study of a building withinground level and five storeys, in accordance with Algerian construction regulations, such as the Algerian Seismic Regulations (RPA 99/2003) and the reinforced concrete regulations (BAEL91; CBA93). This involves considering both the static and dynamic loads induced by earthquakes and studying the phenomenon of building pounding through a dynamic time analysis using a real accelerogram as excitation.

The study is divided in two parts; the first part is devoted to a complete study of a reinforced concrete building for residential use of five storeys located in Khemis El Khchena, an area of medium seismicity according to the RPA99/2003 classification. In the second part, three distinct cases are considered to study the pounding of the buildings. The link between adjacent structures is modeled using a non-linear element called the 'Gap Element', which simulates contact between buildings in case of pounding. A numerical simulation will then evaluate the impact of different gap configurations by displacement and pounding force.

This manuscript is divided into seven chapters.

The first chapter is dedicated to the presentation of the project, including site investigation, geometrical characteristics, material characteristics, etc.

The second, to the preliminary design and load evaluation for secondary and primary elements.

The third chapter presents the calculation of building's secondary elements.

Chapter four is dedicated to the seismic study of the building in accordance with the Algerian seismic regulations (RPA99/2003).

The calculation of the structural elements and study of the building's infrastructure are presented in chapters five and six respectively.

Chapter seven focuses on studying the pounding of building through a nonlinear time-history analysis and the different parameters that influence this phenomenon.

# **Chapter I**

## **Description of the Project**

### I.1 Introduction

The stability of the structure depends on the ability of structural elements such as columns, beams and walls to withstand different stresses (compression, bending, etc.). The type of materials used and their properties, as well as the geometrical characteristics of the structure influence this resistance; therefore, a detailed study of the latter is essential, which is the object of this first chapter.

### I.2 Description of the project

It is a reinforced concrete building for residential use of five storeys, the seismic resistance is insured by shear walls. It is located in Khmis Al Khechna district of Boumerdes, classified as a medium seismic zone (ZONE IIb) according to the RPA99/2003. The building total height is 18.36 meters.

#### I.2.1 Location of the project

The project is located on a site in Khmis Al Khechna.



Figure I-1: Satellite photo

#### I.2.2 Geometrical characteristics

- Building length : 27.50 m
- Building width : 21.80 m
- Ground floor height : 3.06m
- Standard floor height : 3.06m
- Ground floor height : 3.06m
- Total building height : 18.36m

The figures I-2 and I-3 and show the architectural plans of different floors level.

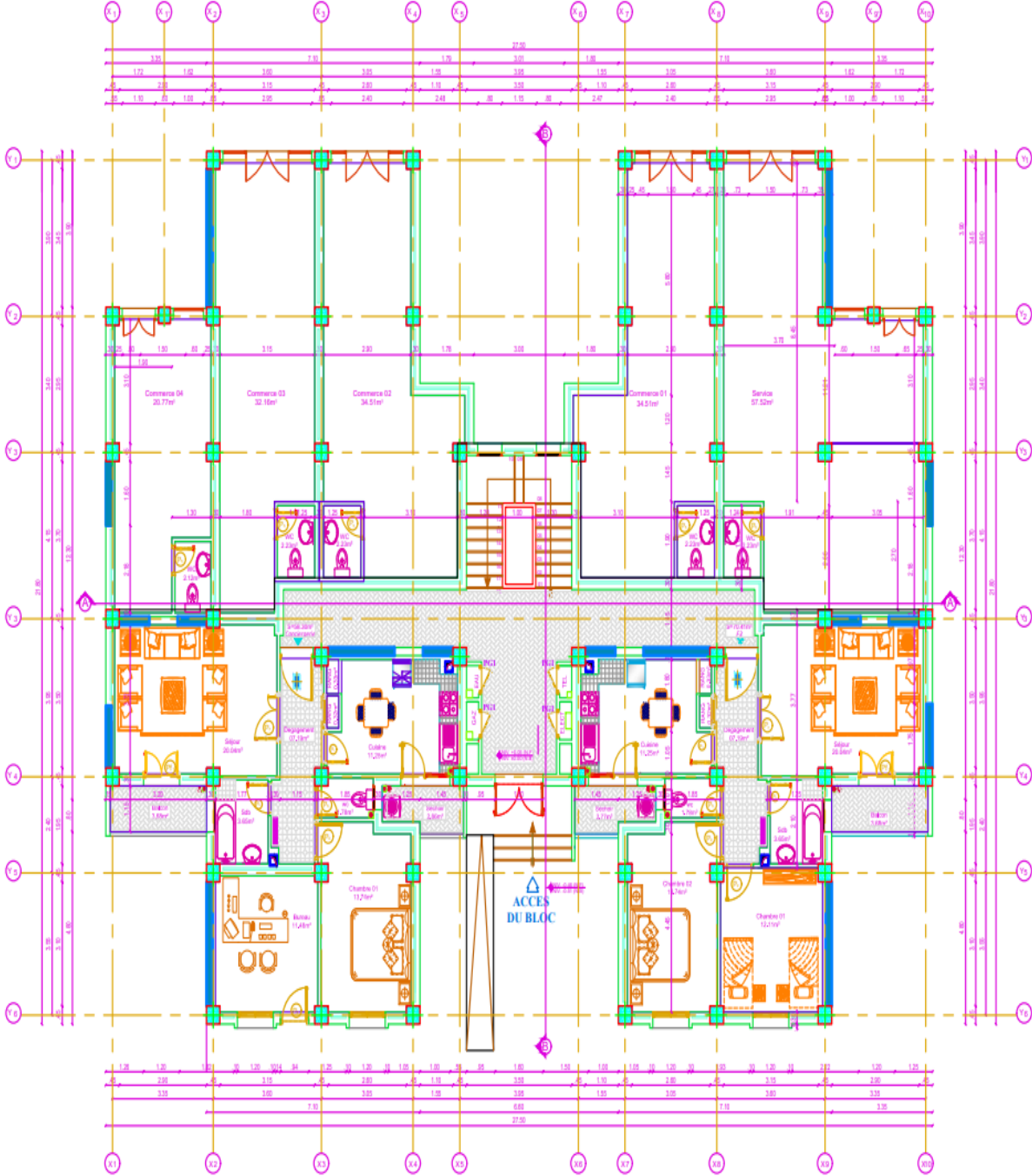

Figure I-2: Architectural plan of the ground floor

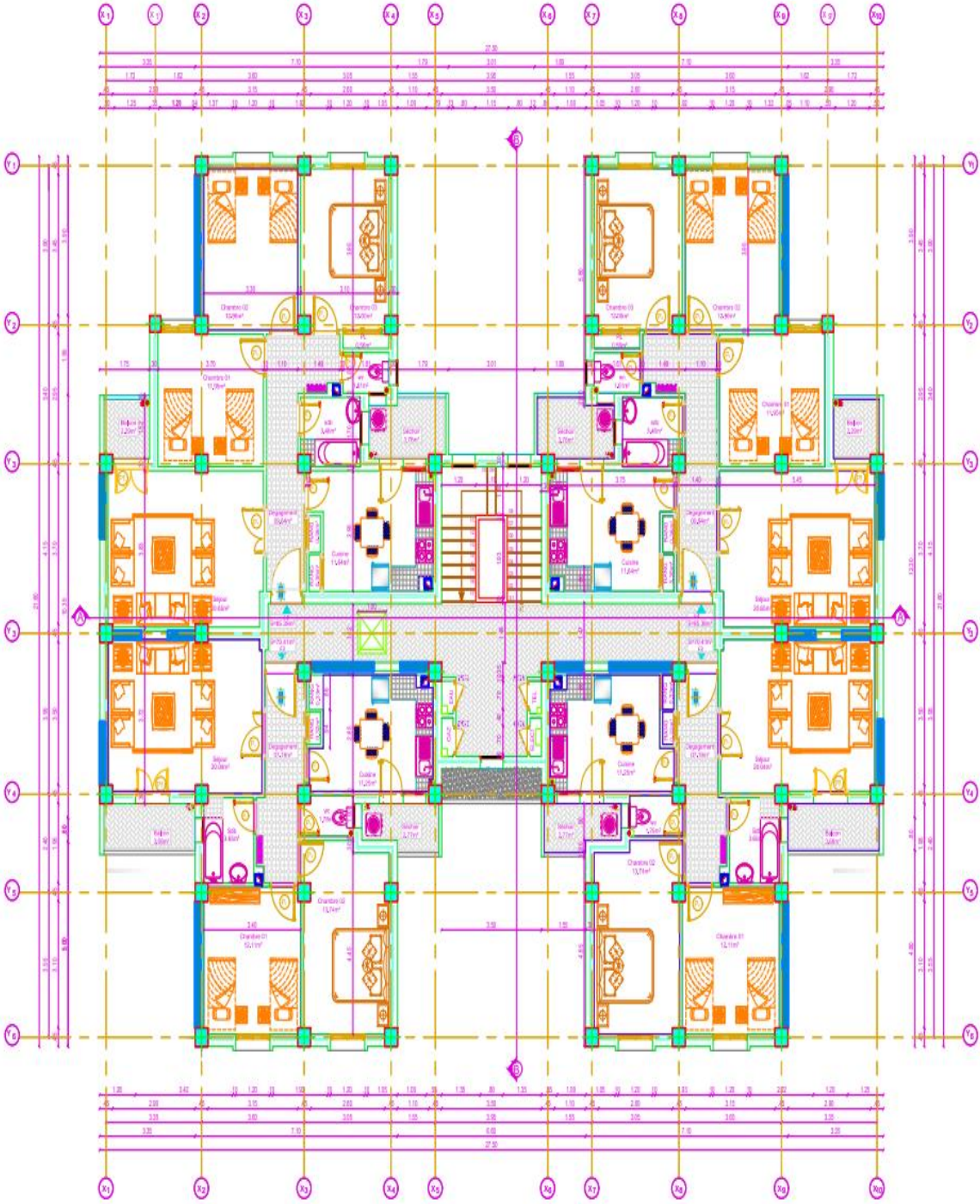

Figure I-3: Standard floor architectural plan

### I.3 Site investigation

The soil study referenced N°069/2018 relating to the geotechnical study made by the national laboratory of housing and construction (LNHC) for the site reserved for the realization of 200 housing AADL in Khmis Al Khechna district of Boumerdes.

The LHCC-ROUIBA laboratory has carried out a three-phase reconnaissance program:

**First phase:** site reconnaissance based on visit reports, on-site observations and studies carried out on neighbouring sites.

**Second phase:** involves reconnaissance work according to the nature of the planned project, specifically two campaigns, namely:

- ✓ In situ tests :
  - Eight (08) bore holes, each one 15.0 meters deep
  - Twenty (20) dynamic penetration tests
  - Three (03) pressiometric boreholes, each one 10.0 meters deep
- ✓ Laboratory tests :
  - Physical identification test: test results are used to derive values for physical parameters such as: dry density, wet density, water content, degree of saturation, liquid limit, plasticity index and grain size.
  - Mechanical identification test: Oedometer compressibility test gives mechanical characteristics: silty clay, consolidation pressure, settlement and swelling coefficient
  - Chemical identification tests: results show zero aggression on foundation concrete.

**Third phase:** interpretation of the results obtained. Conclusions and recommendations relating to the results and the proposed foundation method.

### I.4 Characteristics derived from reconnaissance campaigns

The permissible ground stress and corresponding anchoring depth are given in the following table.

**Table I-1: Admissible ground stress and anchoring height**

Founding depth (m)	Q <sub>adm</sub> (bar)
D = 2.00 m	Q <sub>adm</sub> = 1.90 bars
D = 2.50 m	Q <sub>adm</sub> = 2.00 bars
D = 3.00 m	Q <sub>adm</sub> = 2.20 bars

The site is classified as a soft site; the permissible stress of the subsoil is 2.20 bars at 3.00 meters depth.

### **I.5 Hydrogeological context**

According to the geotechnical investigation carried out by the laboratory, groundwater was detected at a depth of 4.50 meter and above.

### **I.6 Mechanical properties of materials**

The structure will be built in reinforced concrete, so it is important to define the characteristics of the concrete and the steel.

The following characteristics of concrete and steel are obtained from the articles of the CBA 93 and BAEL 91 (modified 99).

#### **I.6.1 Concrete**

The mechanical characteristics under compression at (d) days, noted  $f_{cd}$ , is conventionally defined by:

$$d \leq 28: \quad f_{cj} = \frac{d}{(4.76+0.83d)} f_{c28}$$

$$d > 28: \quad f_{cj} = 1.1 \times f_{c28}$$

A nominal compressive strength of 25 MPa is obtained for 28-day concrete, used for horizontal and vertical elements, thus  $f_{c28} = 25$  MPa

The characteristic tensile strength of concrete at (d) days, noted  $f_{td}$ , is conventionally defined by :

$$f_{td} = 0.6 + 0.06f_{c28}$$

In our case :  $f_{td} = 2.1$  MPa

**I.6.1.1 Limit stress of concrete**

**a) Compressive limit stress :**

✓ **Ultimate limit state :**

The ULS calculation is based on the following parabola-rectangle diagram:

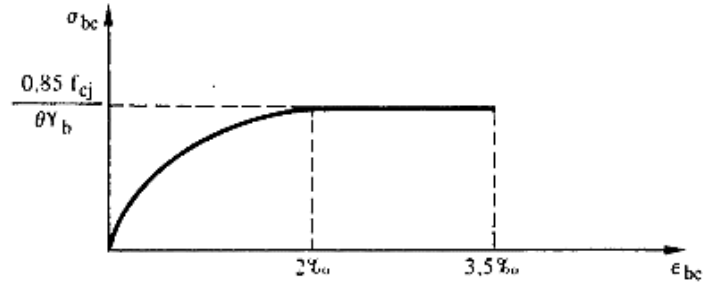

**Figure I-4: Concrete Stress- Deformation Diagram**

The compressive strength of concrete is defined by:

$$f_{bu} = \frac{0.85 f_{c28}}{\theta \gamma_b}$$

$\gamma_b$  : partial safety coefficient for concrete

With:  $\gamma_b = 1.5$  durable or transitory situation  $\rightarrow f_{bu} = 14.17 \text{MPa}$

$\gamma_b = 1.15$  accidental situation  $\rightarrow f_{bu} = 18.47 \text{MPa}$

$\theta$  : coefficient taking into account the duration (t) of load application

$$\theta = 1 \quad \text{for } t > 24 \text{ hours}$$

$$= 0.9 \quad \text{for } t < 24 \text{ hours}$$

$$= 0.85 \quad \text{for } t < 1 \text{ hour}$$

✓ **Serviceability limit state :**

The service limit compressive stress of concrete is given by:

$$\sigma_{bc} = 0.6 f_{c28}$$

In our case:  $\sigma_{bc} = 15 \text{Mpa}$



### b) Permissible shear stress :

Since tangential stresses are only justified in the ultimate limit state, we then have:

- Non-damaging cracking:  $\tau_u = \text{Min} ( 0.2 f_{c28} / \gamma_b , 5 \text{ MPa} ) = 3.33 \text{ MPa}$
- Detrimental cracking:  $\tau_u = \text{Min} ( 0.2 f_{c28} / \gamma_b , 5 \text{ MPa} ) = 3.33 \text{ MPa}$
- Very detrimental cracking :  $\tau_u = \text{Min} ( 0.15 f_{c28} / \gamma_b , 4 \text{ MPa} ) = 2.50 \text{ Mpa}$

### I.6.1.2 Longitudinal deformation of concrete

- Instantaneous longitudinal modulus of elasticity  $E_{id}$  :

$$E_{id} = 11000 (f_{cd})^{1/3} \quad \text{for loads applied for less than 24h}$$

$$E_{id} = 32164.2 \text{ MPa}$$

- Long-term modulus of elasticity  $E_{vd}$  :

$$E_{vd} = E_{id} / 3 = 10721.4 \text{ MPa}$$

### I.6.1.3 Poisson coefficient

$$\nu = 0.20 \quad \text{for ultimate limit state.}$$

$$\nu = 0 \quad \text{for Service limit state.}$$

## I.6.2 Steel

Three types of reinforcement are used:

- Re - bar (R.B), Fe E 235 grade
- Deformed bar (D.B), grade Fe E 500
- Welded wire mesh (W.M), grade Fe E 500

Fe: yield stress of steel = 500MPa

**I.6.2.1 Ultimate limit stress**

The steel calculation diagram is deduced by performing an affinity parallel to the tangent at the origin in the ratio  $1/ \mathbf{Y}_s$ , as shown in the following figure.

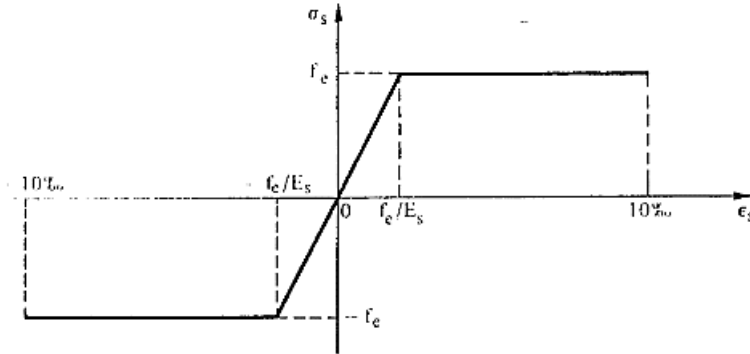

**Figure I-5: Stress-Deformation Diagram for Steel**

The behavior of steels in ULS calculations is based on a perfect elasto-plastic law, with :

$$\left\{ \begin{array}{ll} \sigma_s = f_e / \mathbf{Y}_s & \text{for : } \epsilon_{cs} < \epsilon_s < 10 \\ \sigma_s = E_s \cdot \epsilon_s & \text{for : } \epsilon_s < \epsilon_{cs} \end{array} \right.$$

Where,  $\epsilon_{cs} = f_e / \mathbf{Y}_s E_s$

With,

$\epsilon_s$ : Relative stretch.

$E_s$  : The longitudinal modulus of elasticity of steel = 200 000 N/mm

$\mathbf{Y}_s$ : partial safety coefficient for steels

For high-adhesion and smooth-round reinforcement:

$$\left\{ \begin{array}{l} \mathbf{Y}_s = 1.15 \text{ durable or transition situation : } \sigma_s = 434 \text{ MPa} \\ \mathbf{Y}_s = 1.00 \text{ accidental situation : } \sigma_s = 500 \text{ MPa} \end{array} \right.$$

**I.6.2.2 Serviceability limit stress**

The cracks to be considered are :

- Non-detrimental cracking: no limit other than that imposed by the ULS.
- Very detrimental cracking:  $\sigma_s < \text{Min} [ 2/3 f_e ; 110 ]$ .
- Very detrimental cracking:  $\sigma_s < \text{Min} [ 1/2 f_e ; 90 \sqrt{\eta \cdot f_{td}} ]$

With,  $\eta$  : cracking coefficient = 1.6 for D.B  
= 1.0 for R.B

### I.7 Actions to be taken into account

The actions taken into account for the study are:

- Permanent loads resulting from the elements' own weight;
- Variable loads and thermal gradients;
- Accidental loads;
- Static loads exerted by the ground on walls;
- Snow and wind effects;
- Earthquake effects;
- Operating overloads.

### I.8 Load combinations

Action combinations are sets of actions to be considered simultaneously, and represent a necessary step in determining the solicitations due to the elements.

The combinations to be considered for determining design loads and deformations in accordance with RPA 99/2003 are:

✓ **The fundamental combinations:**

ULS:  $1.35 G + 1.5 Q$

SLS:  $G + Q$

✓ **Accidental combinations :**

$0.8 G + E_x$

$0.8 G + E_y$

$G + Q + E_x$

$G + Q + E_y$

With: G: Permanent loads.

Q: Operating loads

E: earthquake action

### **I.9 Used Regulations**

- RPA: Algerian aseismic rules 99 modified in 2003.
- BAEL 91 (modified in 99): Technical rules for the design and calculation of reinforced concrete structures using the limit states method.
- CBA 93: design and calculation rules for reinforced concrete structures.
- DTR B.C.2.2 : Permanent loads and operating loads.

### **I.10 Conclusion**

This chapter has allowed us to define our project as well as the characteristics of the materials used in its construction, mainly concrete and steel. The advantages of concrete and the mechanical and physical properties of steel justify the selection of these materials, ensuring a solid and reliable construction.

**Chapter II**  
**Preliminary Sizing**  
**of the Structure's**  
**Elements**

### II.1 Introduction

Preliminary sizing is a necessary step in the study of a reinforced concrete project. Its purpose is to estimate the sections of structural elements (floor slabs, beams, columns and walls). These dimensions are chosen in accordance with the recommendations of BAEL91 and verification in conformity with RPA99/2003.

This step allows a rapid balancing of feasibility, efficiency and cost before embarking on a detailed analysis

### II.2 Preliminary sizing of floors

#### II.2.1 Hollow-core slab

The hollow-core slab is a type of reinforced concrete slab commonly used in construction for its advantages in terms of weight reduction and cost, while maintaining good load-bearing capacity.

It is made of joists on which the hollow core rests, and a compression slab. The floor thickness is obtained using the following empirical formula:

$$h_t \geq \frac{L}{22.5}$$

L: the longest beam span

$$L = \min (L_{\max,x} ; L_{\max,y}) = 460 \text{ cm}$$

$h_t$  : total height

Therefore:

$$h_t \geq 20.4 \text{ cm}$$

➔ The hollow-core slab will consist of a 16 cm concrete slab and a 5 cm compression slab.

#### II.2.2 Reinforced concrete solid slab

Solid concrete floors are made from a continuous slab of reinforced concrete, it provide a durable and strong surface capable of supporting significant loads suitable for various

## Chapter II. Preliminary sizing of structural elements

---

applications. In our case, this type of floor is used for balconies, the thickness of which must verify:

- ✓ Flexural strength:

$$\alpha = \frac{L_x}{L_y}$$

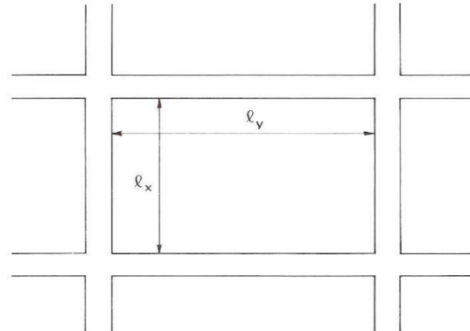

With,

$L_x$ : the short span of a reinforced concrete slab panel measured between bearing points.

$L_y$ : the long span of a reinforced concrete slab panel measured between bearing points.

$\alpha < 0.4$  : the slab carries in one direction only

$0.4 \leq \alpha \leq 1$ : the slab carries on both directions

In our case:  $L_x = 125\text{cm}$ ;  $L_y = 145\text{cm}$  therefore:  $\alpha = 125/145 = 0.86 > 0.4$

As the slab is carried on simple supports:

$$e_{\text{slab}} \geq L_x / 20 = 6.25 \text{ cm}$$

- ✓ Fire safety condition :

$e = 7 \text{ cm}$  for one-hour fire protection

$e = 11\text{cm}$  for two-hours fire protection

- ✓ Acoustic isolation requirements:

To ensure good sound insulation, the floor thickness must meet a minimum requirement, according to CBA93, the floor thickness must be greater than 13 cm.

➔ The thickness adopted for the floor in our project is 15 cm.

### Summary:

For our study the Preliminary sizing of floor adopted are:

- ✓ (16 + 5) cm for hollow body slab.
- ✓ 15 cm for solid slab.

### II.3 Load evaluation

This step consists in determining the permanent and operating loads that will act on the structure during its service life.

✓ **Permanent load :**

- Typical floor :

**Table II-1: Evaluation of typical floor loads**

<b>Componentes</b>	<b>Weight per volume [kN/m<sup>3</sup>]</b>	<b>G [kN/m<sup>2</sup>]</b>
Tiles 2cm	22	0.44
Bedding mortar 2cm	20	0.40
Layer of sand 3cm	18	0.54
Hollow body (16+5)cm	14	2.94
Coating 2cm	10	0.2
Partition	/	1
<b>Permanent load</b>		<b>5.52</b>

- R.C solid slab :

**Table II-2: Evaluation of balcony loads**

<b>Componentes</b>	<b>Weight per volume [kN/m<sup>3</sup>]</b>	<b>G [kN/m<sup>2</sup>]</b>
Tiles 2cm	22	0.44
Bedding mortar 2cm	20	0.40
Sand bed 3cm	18	0.54
R.C slab 15cm	25	3.75
Coating 2cm	10	0.2
Partition	/	1
<b>Permanent load</b>		<b>6.63</b>



## Chapter II. Preliminary sizing of structural elements

- Terrace floor :

**Table II-3: Evaluation of terrace floor loads**

<b>Componentes</b>	<b>Weight per volume [kN/m<sup>3</sup>]</b>	<b>G [kN/m<sup>2</sup>]</b>
Rolled gravel protection 4cm	20	0.8
Multilayer waterproofing 2cm	6	0.12
Lightweight concrete slope 10cm	22	2.20
Thermal insulation 4cm	4	0.16
Hollow body (16+5)cm	14	2.94
Gypsum plaster 2cm	10	0.20
Vapor barrier 2cm	1.2	0.06
<b>Permanent load</b>		<b>6.48</b>

- Reinforced concrete wall :

**Table II-4: Evaluation of reinforced concrete wall loads**

<b>Componentes</b>	<b>Weight per volume [kN/m<sup>3</sup>]</b>	<b>G [kN/m<sup>2</sup>]</b>
Dead weight	25	5
Cement plaster 2cm	18	0.36
Gypsum plaster 2cm	10	0.2
<b>Permanent load</b>		<b>5.56</b>

- Cavity masonry wall :

The weight per linear meter of a cavity masonry wall in hollow clay brick (15+10) cm is given in the following table.

**Table II-5: Evaluation of wall load**

<b>Layers</b>	<b>Weight per volume [kN/m<sup>3</sup>]</b>	<b>G [kN/m<sup>2</sup>]</b>
Bricks (15+10)cm	9	2.25
Cement plaster 3cm	18	0.54
Gypsum plaster 2cm	10	0.2
<b>Permanent load</b>		<b>3</b>

✓ Operating overloads

Table II-6: Evaluation of operating loads

	Typical floor	Non-accessible terrace	Balcony	Staircase	Commercial floor
Overloads [kN/m <sup>2</sup> ]	1.5	1	3.5	2.5	4

## II.4 Stairs

A stair is a set of steps leading from one floor to the other. It is provided to afford the means of ascent and descent between various floors of a building. The room of the building, in which the stair is located, is known as stair-case. The space occupied by the stair is a stairway. Stair may be constructed of bricks, steel or reinforced concrete.

The reinforced concrete stairs offer a number of benefits, including the ability to withstand fire. They can also be made with any height and larger widths or spans.

### II.4.1 Stairs terminology

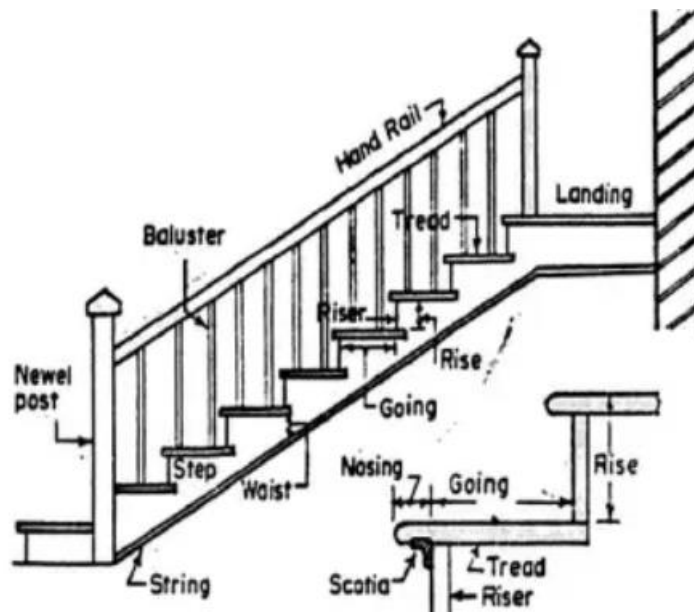

Figure II-1: Section of a stair, with its components

## Chapter II. Preliminary sizing of structural elements

---

- **Step:** It is a portion of stair, which permits ascent or descent. A stair is composed of a set of steps.
- **Tread:** It is the upper horizontal portion of a step upon which the foot is placed while ascending or descending.
- **Riser:** It is the vertical portion of a step providing a support to the tread.
- **Flight:** This is defined as an unbroken series of steps between floors or between floor and landings, or between landing and landing.
- **Landing:** It is the level platform at the top or bottom of a flight between the floors. A landing facilitates change of direction and provides an opportunity for taking rest during the use of the stair.
- **Rise:** It is the vertical distance between two successive tread faces.
- **Going:** It is the horizontal distance between two successive riser faces.

### II.4.2 Dimensions

#### ✓ Height and tread:

Assuming:  $h = 17\text{cm}$ , we have  $H_v = 136\text{ cm}$

Knowing that:  $n \times h = 136\text{ cm} \rightarrow n = 8\text{ risers}$

$n' = n - 1 = 7\text{ steps}$

$n' \times g = 213\text{ cm} \rightarrow g = 30\text{cm}$

Verification of Blondel's formula:

$$58\text{ cm} \leq g + 2h = 64 \leq 64\text{ cm} \rightarrow \text{Condition checked}$$

#### ✓ The overlap:

$$L_r = g (N_c - 1) = 30 (8 - 1) = 210\text{ cm}$$

#### ✓ The angle of inclination of the flight (the slope):

$$\theta = \tan^{-1} \frac{H_v}{L_r} = \tan^{-1} \frac{136}{210} = 33^\circ$$

#### ✓ The length of the flight :

$$L_v = \frac{H_v}{\sin\theta} = \frac{136}{\sin 33} = 249.7\text{ cm}$$

### ✓ Stair thickness :

The thickness of the flight of stairs is obtained from the following considerations:

$$e \geq \max \left\{ \frac{L_0}{25}; \frac{L_0}{30} \right\}$$

With,  $L_0$  : developed length  $\rightarrow L_0 = L_v + 150 = 399.7$  cm

$$e \geq \max \left\{ \frac{399.7}{25}; \frac{399.7}{30} \right\} = 15 \text{ cm}$$

We adopt :  $e = 15$ cm

The thickness of the landing is obtained from the following considerations:

$$e \geq \max \left\{ \frac{150}{25}; \frac{150}{30} \right\} = 6 \text{ cm}$$

We adopt :  $e = 15$ cm

### II.4.3 Evaluation of permanent loads and overloads of stairs

The evaluation of permanent loads and overloads of stairs are resumed in following tables.

- Landing :

**Table II-7: Loads and overloads evaluation for landing**

Componentes	Weight per volume [kN/m <sup>3</sup> ]	G [kN/m <sup>2</sup> ]
Tile 2cm	22	0.44
Bedding mortar 2cm	20	0.4
Sand bed 3cm	18	0.54
Landing 15cm	15	3.75
Cement plaster 2cm	18	0.36
<b>Permanent load</b>		<b>5.49</b>
<b>Overload</b>		<b>2.50</b>

## Chapter II. Preliminary sizing of structural elements

- Flight of stairs + step:

**Table II-8: Loads and overloads evaluation for steps**

Componentes	Weight per volume [kN/m <sup>3</sup> ]	G [kN/m <sup>2</sup> ]
Tile 2cm	22	0.44
Bedding mortar 2cm	20	0.4
Step h / 2 = 8.5cm	22	1.87
Stair bench $\frac{e=15}{\cos 33} = 17.88\text{cm}$	25	4.45
Cement plaster 2cm	18	0.36
<b>Permanent load</b>		<b>7.52</b>
<b>Overload</b>		<b>2.50</b>

### Summary of stairs dimensions:

After having evaluated the loads and overloads of the staircases, we can conclude that :

- ✓ A thickness of  $e = 15$  cm has been chosen for the Flight of stairs.
- ✓ A step height of 17cm and a tread  $g = 30$ cm have been adopted.
- ✓ A permanent load of  $G = 7.52$  kN/m<sup>2</sup> for flight of stairs and  $G = 5.49$  kN/m<sup>2</sup> for the landing.

### II.5 Preliminary sizing of the parapet

The parapet is a low protective wall that extend above the edge of a roof, balcony, terrace or other elevated structures. It is designed to ensure safety and to protect against rainwater infiltration.

The weight of the parapet is calculated as follows:

$$P_{\text{parapet}} = \left[ 0.12 \left( \frac{0.07+0.1}{2} \right) + 0.1 \times 0.5 \right] \times 25 + (0.5 + 0.12 + 0.07 + \sqrt{(0.12)^2 + (0.1 - 0.07)^2} + 0.1 + 0.6) \times 0.03 \times 18$$

$$P_{\text{parapet}} = 2.57 \text{ kN/ml}$$

The parapet operating load is taken from DTR B.C.2.2 :

$$Q = 1 \text{ kN/m}$$

### II.6 Preliminary sizing of beams

A beam is a structural member that resists primarily lateral loads, assumed to be uniformly distributed, but sometimes these same loads can be point loads, located on the floors to transmit them to the columns and walls.

According to B.A.E.L 91, in the case of residential buildings, the Preliminary sizing of beams is given by the following empirical formulas:

$$\frac{L_{\max}}{15} \leq h \leq \frac{L_{\max}}{10}$$

$$0.3h \leq b \leq 0.7 h$$

According to RPA99/2003, beams must comply with the following conditions:

$$h \geq 30\text{cm}$$

$$b \geq 20\text{cm}$$

$$h/b \leq 4$$

$$b_{\max} \leq 1.5h + b_1$$

With,

h: total height of the beam

b: width of beam base

- Calculation in the x-direction :

$$\frac{461}{15} \leq h \leq \frac{461}{10} \quad \rightarrow \quad h = 40 \text{ cm}$$

$$-0.3 \times 40 \leq b \leq 0.7 \times 40 \quad \rightarrow \quad b = 30 \text{ cm}$$

Verification according to RPA99/2003 :

$$h = 40\text{cm} \geq 30\text{cm}$$

$$b = 30 \geq 20\text{cm}$$

$$h/b = 40/30 \leq 4$$

- Calculation in the y-direction:

$$\frac{510}{15} \leq h \leq \frac{510}{10} \quad \rightarrow \quad h = 45 \text{ cm}$$

## Chapter II. Preliminary sizing of structural elements

---

$$0.3 \times 45 \leq b \leq 0.7 \times 45 \rightarrow b = 30\text{cm}$$

Verification according to RPA99/2003:

$$h = 45\text{cm} \geq 30\text{cm}$$

$$b = 30 \geq 20\text{cm}$$

$$h/b = 45 / 30 \leq 4$$

**Summary of beams sections:**

**Table II-9: Dimensions of principal and secondary beams**

	<b>Orientation</b>	<b>Dimensions cm<sup>2</sup></b>
<b>Principal beam</b>	Parallel to YY	30 × 45
<b>Secondary beam</b>	Parallel to XX	30 × 40

### II.7 Shear wall Preliminary sizing

A Shear wall is a spatial structure whose thickness is very small compared to the other two dimensions. It is a structural element designed to counteract horizontal forces such as seismic loads, providing stability to the building.

According to article 7.7.1 of RPA99/ 2003, elements are considered to be shear walls if the condition  $l \geq 4a$  is satisfied. The minimum dimensions depend on the clear height of the story and the stiffness conditions at the ends as showed in figure II-2.

$$\left\{ \begin{array}{l} l \geq 4a ; \\ a \geq 15 \text{ cm} ; \\ a \geq \max\left\{\frac{h_e}{22} ; \frac{h_e}{20}\right\} = 15.3 \text{ cm.} \end{array} \right.$$

$h_e$ : clear story height = 306

$l$ : wall length.

$a$ : wall thickness

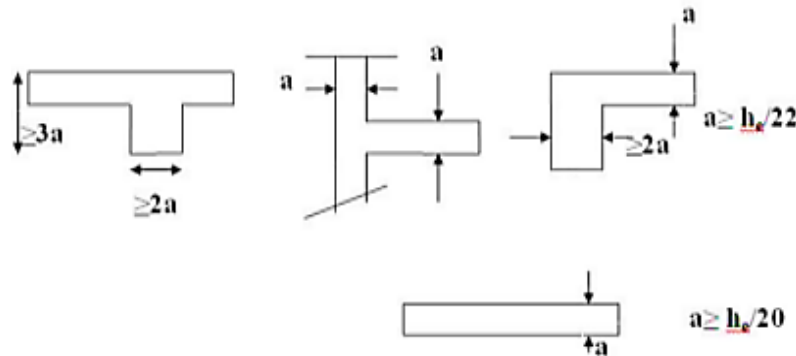

Figure II-2: Section of shear wall in plan

We adopt a wall thickness of 20 cm in both directions and a length « l » greater than 80cm

### II.8 Preliminary sizing of columns

Columns are vertical structural elements designed to transfer loads from beams, floors, and roof down to the foundation, they are a fundamental components in construction, providing the essential support and ensuring the stability of the structure.

Columns are Preliminary sized by checking the resistance of an intuitively chosen section with a reinforcement section of 0.9% of the concrete section (RPA99/2003) under the action of the maximum normal force.

This maximum normal force at ULS,  $N_u = 1.35G + 1.5Q$ , is calculated in centered compression using the vertical degression rule.

According to Art.B.8.4.1 of the B.A.E.L 91 (modified in 99), the ultimate normal force  $N_u$  acting on columns subjected to centered compression must be at most equal to the following value:

$$\bar{N}_{ult} = \alpha \left[ \frac{B_r * f_{c28}}{0.9 * \gamma_b} + A_s \frac{f_e}{\gamma_s} \right]$$

With,

$B_r$ : reduced column cross-section calculated from the actual column dimensions reduced by 1cm thickness over the entire periphery as illustrated in figure III-3.

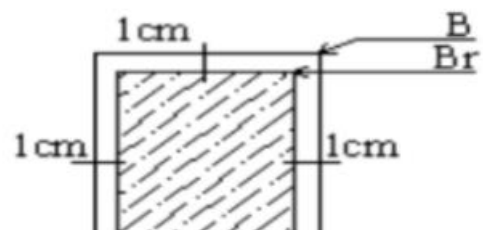

Figure II-3:Reduced column cross-section



## Chapter II. Preliminary sizing of structural elements

---

$A_s$  : longitudinal reinforcement of the column taken equal to 0.9% of the column section for zone IIb (RPA 7.4.2.1) :  $A_s = 9B/1000$

$Y_b=1.5, Y_s=1.15$

$f_{c28}$  and  $f_e$ : characteristic strengths of concrete and steel

$\alpha$  : coefficient depending on mechanical slenderness, which takes the values :

$$\alpha = \frac{0.85}{1+0.2\left(\frac{\lambda}{35}\right)^2} \quad \text{for } \lambda \leq 50$$

$$\alpha = 0.6 \left(\frac{50}{\lambda}\right)^2 \quad \text{for } 50 \leq \lambda \leq 70$$

Where,  $\lambda = \frac{L_f}{i} = \frac{L_f \sqrt{12}}{b}$

$i$ : gyration momentum.

$I$  : moment of inertia.

$\lambda$  : geometric slenderness.

$L_f$ : buckling length =  $0.7 \times h_e$  (column embedded in a foundation).

### - **Load distribution :**

The cross-section of the columns adopted for all floors is ( $45 \times 45 \text{ cm}^2$ ), and knowing the floor surface (area of influence) taken up by this column (the most heavily loaded), we calculate the permanent loads (G) taken up by it and add the operating surcharges (Q) using the degression rule.

### - **Law of degression of operating charges :**

According to article 6.3 of DTR B.C.2.2, the operating load of each floor is reduced by 10% per floor up to 0.5 Q.

The following table summarizes Law of degression of operating loads for the three columns.

Table II-10: Law of degression of operating loads

Level	Variable loads				
	Qi	Q Cumulated	Q (kN)		
			P1	P2	P3
Under terrace	1	1	14.09	6.804	3.51
Under 5 <sup>th</sup> floor	1.5	2.5	35.23	17.01	8.77
Under 4 <sup>th</sup> floor	1.5	3.85	54.26	26.20	13.51
Under 3 <sup>rd</sup> floor	1.5	5.05	71.17	34.36	17.72
Under 2 <sup>nd</sup> floor	1.5	6.1	85.97	41.50	21.41
Under 1 <sup>st</sup> floor	1.5	6.85	96.54	46.61	24.04

- Calculation of ultimate normal force :

The section chosen so that the column can withstand the following ultimate normal force:

$$\lambda = \frac{0.7 * 2.61 * \sqrt{12}}{0.45} = 14.06 < 35$$

$$\alpha = \frac{0.85}{1 + 0.2 \left( \frac{16.49}{35} \right)^2} = 0.82$$

$$\overline{Nult} = 0.82 \left[ \frac{0.43^2 * 25}{0.9 * 1.5} + \frac{9 * 0.45^2 * 500}{1.15 * 1000} \right] = 3457,50 \text{ KN}$$

- Normal effort due to loads and operating loads :

There are three columns; the floor area covered by these most solicited columns is given in the following figures.

a) Central column ( $45 \times 45$  cm<sup>2</sup>):

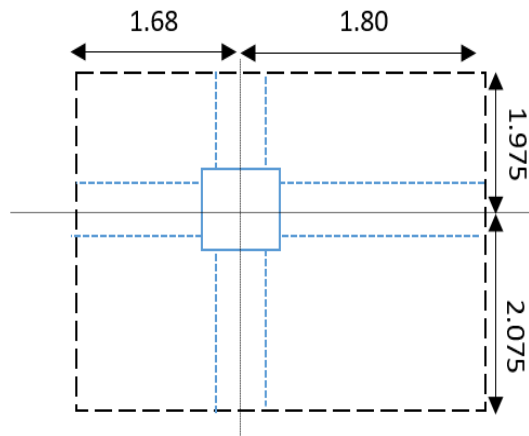

Figure II-4: Floor area tributary to the most loaded central column

The following table summarizes the floor area tributary to the most loaded central column with the weight of the floors.

Table II-11: Surface area and weight of the typical floor and terrace tributary to the most loaded central column

Influence area (m <sup>2</sup> )	Weight of terrace floor (kN)	Weight of typical floor (kN)
14.094	91.33	77.80

The following table summarizes the volume and weight of the principal and secondary beams.

Table II-12: Volume and weight of the principal and secondary beams supported by the most loaded central column

<b>Principal beam</b>	Volume (m <sup>3</sup> )	0.546
	Weight of beam (kN)	13.668
<b>Secondary beams</b>	Volume (m <sup>3</sup> )	0.417
	Weight of beam (kN)	10.425

The following table summarizes the loads and overloads as well as the ultimate normal effort, taking into account an increase of 1.1 for a line of columns adjacents to the edge columns.

Table II-13: Normal effort due to the load distribution

Level	Variable loads	Permanent load					1.1 * Nu (kN)	$\bar{N}_{ult}$ (kN)
	Q (kN)	P floor	P beams	P column	G (kN)	G cumulated		
Under terrace	14.09	91.32	24.1	/	115.42	115.42	194.66	3457.5
Under 5 <sup>th</sup> floor	35.23	77.79	24.1	15.5	117.39	232.82	403.88	3457.5
Under 4 <sup>th</sup> floor	54.26	77.79	24.1	15.5	117.39	350.22	609.61	3457.5
Under 3 <sup>rd</sup> floor	71.17	77.79	24.1	15.5	117.39	467.62	811.85	3457.5
Under 2 <sup>nd</sup> floor	85.97	77.79	24.1	15.5	117.39	585.02	1010.61	3457.5
Under 1 <sup>st</sup> floor	96.54	77.79	24.1	15.5	117.39	702.41	1202.38	3457.5

The results show that:

$$N_u = 1202.38 \text{ kN} < \bar{N}_{ult} = 3457.5 \text{ kN} \quad \rightarrow \quad \text{The condition is checked}$$

b) Boundary column (45 × 45) cm<sup>2</sup>:

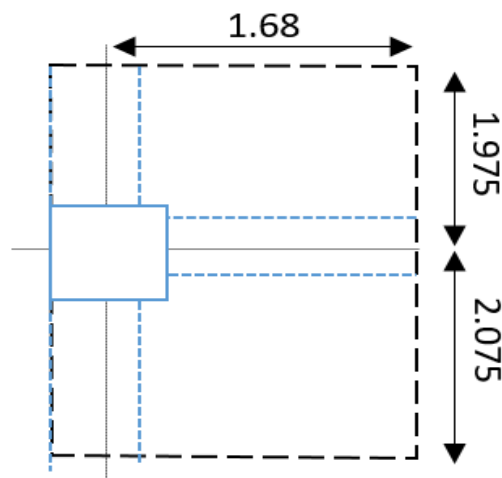

Figure II-5: Floor area tributary to the most loaded Boundary column

## Chapter II. Preliminary sizing of structural elements

The following table summarizes the floor area tributary to the most loaded boundary column with the weight of the floors.

**Table II-14: Surface area and weight of the typical floor and terrace tributary to the most loaded boundary column**

Influence area (m <sup>2</sup> )	Weight of terrace floor (kN)	Weight of typical floor (kN)
6.804	44.09	37.56

The following table summarizes the volume and weight of the principal and secondary beams.

**Table II-15: Volume and weight of the principal and secondary beams supported by the most loaded boundary column**

<b>Principal beam</b>	Volume (m <sup>3</sup> )	0.546
	Weight of beam (kN)	13.668
<b>Secondary beams</b>	Volume (m <sup>3</sup> )	0.201
	Weight of beam (kN)	5.04

The following table summarizes the loads and overloads as well as the ultimate normal effort.

**Table II-16: Normal effort due to the load distribution**

Level	Variable loads	Permanent load							Nu (kN)	$\overline{N_{ult}}$ (kN)
	Q (kN)	P par apert	P floor	P beams	P wall	P column	G (kN)	G cumulated		
<b>Under terrace</b>	6.804	10.41	44.08	18.7	/	/	73.18	73.18	119.93	3457.5
<b>Under 5<sup>th</sup> floor</b>	17.01	/	37.56	18.7	7.98	15.5	79.74	146.37	250.45	3457.5
<b>Under 4<sup>th</sup> floor</b>	26.20	/	37.56	18.7	7.98	15.5	79.74	226.11	386.64	3457.5

## Chapter II. Preliminary sizing of structural elements

<b>Under 3<sup>rd</sup> floor</b>	34.36	/	37.56	18.7	7.98	15.5	79.74	305.85	519.66	3457.5
<b>Under 2<sup>nd</sup> floor</b>	41.50	/	37.56	18.7	7.98	15.5	79.74	385.59	649.50	3457.5
<b>Under 1<sup>st</sup> floor</b>	46.61	/	37.56	18.7	7.98	15.5	79.74	465.33	773.01	3457.5

The results show that:

$$N_u = 773.01 \text{ kN} < \bar{N}_{ult} = 3457.5 \text{ kN} \quad \rightarrow \quad \text{The condition is checked}$$

### c) Corner column ( $45 \times 45$ ) $\text{cm}^2$ :

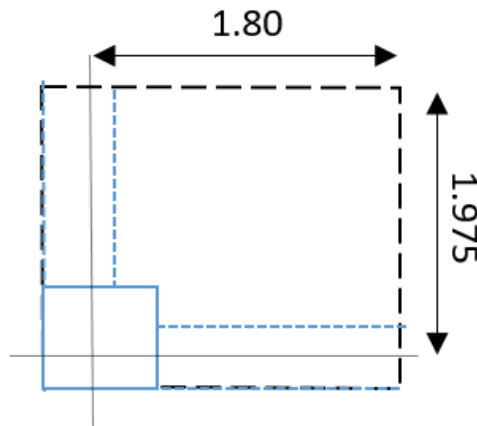

**Figure II-6: Floor area tributary to the most loaded corner column**

The following table summarizes the floor area tributary to the most loaded corner column with the weight of the floors.

**Table II-17: Surface area and weight of the typical floor and terrace tributary to the most loaded corner column**

<b>Influence area (<math>\text{m}^2</math>)</b>	<b>Weight of terrace floor (kN)</b>	<b>Weight of current floor (kN)</b>
3.51	22.74	19.37

The following table summarizes the volume and weight of the principal and secondary beams.

## Chapter II. Preliminary sizing of structural elements

**Table II-18 : Volume and weight of the principal and secondary beams supported by the most loaded corner column**

<b>Principal beam</b>	Volume (m <sup>3</sup> )	0.266
	Weight of beam (kN)	6.66
<b>Secondary beams</b>	Volume (m <sup>3</sup> )	0.216
	Weight of beam (kN)	5.40

The following table summarizes the loads and overloads as well as the ultimate normal effort.

**Table II-19: Normal effort due to the load distribution**

Level	Variable loads	Permanent load							Nu (kN)	$\bar{N}_{ult}$ (kN)
	Q (kN)	P acrot ere	P floor	P beams	P wall	P colu mn	G (kN)	G cumulat ed		
<b>Under terrace</b>	3.51	9.63	22.74	12.06	/	/	44.43	44.43	65.24	3457.5
<b>Under 5<sup>th</sup> floor</b>	8.77	/	19.37	12.06	11.25	15.5	58.18	102.61	151.67	3457.5
<b>Under 4<sup>th</sup> floor</b>	13.51	/	19.37	12.06	11.25	15.5	58.18	160.79	237.33	3457.5
<b>Under 3<sup>rd</sup> floor</b>	17.72	/	19.37	12.06	11.25	15.5	58.18	218.97	322.18	3457.5
<b>Under 2<sup>nd</sup> floor</b>	21.41	/	19.37	12.06	11.25	15.5	58.18	277.15	406.26	3457.5
<b>Under 1<sup>st</sup> floor</b>	24.04	/	19.37	12.06	11.25	15.5	58.18	335.33	488.75	3457.5

The results show that:

$$N_u = 488.75 \text{ kN} < \bar{N}_{ult} = 3457.5 \text{ kN} \quad \rightarrow \quad \text{The condition is checked}$$

## Chapter II. Preliminary sizing of structural elements

- Verification of the dimensions:

According to article 7.4.1 of RPA99/2003 the dimensions of the cross-section of the columns must satisfy the following conditions:

$$\text{Min } (b_1, h_1) \geq 25\text{cm} \quad \text{in zone I et IIa}$$

$$\text{Min } (b_1, h_1) \geq 30\text{ cm} \quad \text{in zone IIb et III}$$

$$\text{Min } (b_1, h_1) \geq h_e/20$$

$$1/4 < b_1/h_1 < 4$$

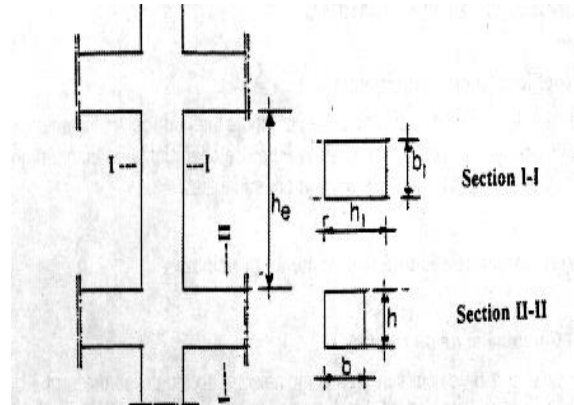

Figure II-7: Formwork of columns

For a column with a section of  $(45 \times 45) \text{ cm}^2$ :

- ✓  $\text{Min } (b_1, h_1) = 45 \text{ cm} \geq 30 \text{ cm}$
- ✓  $\text{Min } (b_1, h_1) = 45 \text{ cm} \geq 13.0 \text{ cm}$
- ✓  $1/4 < b_1/h_1 = 1 < 4$

Therefore, the conditions are checked.

### II.9 Conclusion

This chapter has allowed us to preliminary size the elements of our structure in conformity to the Algerians regulations (BAEL99 and RPA99/2003). The table below summarize the dimensions:

Table II-20: Preliminary sizing of elements

Elements	Preliminary sizing		
<b>Floor</b>	Hollow core slab : (16+5) cm		solid slab : 15 cm
<b>Stairs</b>	Height : 17 cm	tread : 30 cm	thickness : 15 cm
<b>Beams</b>	Principal : $30 \times 45 \text{ cm}^2$		secondary : $30 \times 40 \text{ cm}^2$
<b>Shear wall</b>	$l > 80\text{cm}$		$e = 20\text{cm}$
<b>Columns</b>	45 × 45		40 × 40 (2 columns)



**Chapter III**  
**Study of Secondary**  
**Elements**

### III.1 Introduction

Secondary elements are components that do not play a primary role in load bearing, but remain indispensable for completing the main elements and ensuring the comfort and functionality of the entire building.

According to the BAEL 91, the calculation of secondary elements is carried out under the action of permanent loads and live loads. They must also comply with the constructive provisions of the parasitic regulations RPA99/2003.

### III.2 Floor study

In our study, we have two types of floor:

- Hollow core slab
- Solid slab for balconies

#### III.2.1 Hollow core slab

The floors in our building consist of a 16 cm concrete slab plus a 5 cm compression slab, coupled with joists, which are calculated in simple bending as a T-section. If certain prerequisites are satisfied, the flat-rate computation approach is applicable:

- ✓ The operating load is not more than twice the permanent load or  $5000 \text{ N/m}^2$  :

$$q \leq 2 g \text{ and } q \leq 5 \text{ kN/m}^2$$

- ✓ The floor elements have the same inertia in the different spans.
- ✓ Successive spans comply with the following ratios :

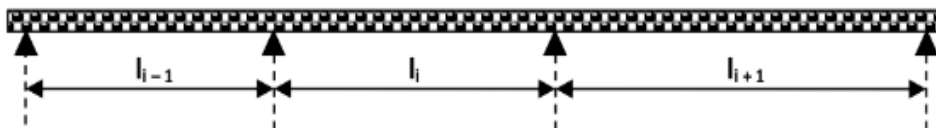

**Figure III-1: Diagram of beam span**

$$0,8 \leq l_i / l_{i-1} \leq 1,25$$

$$0,8 \leq l_i / l_{i+1} \leq 1,25$$

### Chapter III. Study of secondary elements

---

✓ Cracking does not compromise the strength of the cladding or partitions.

- **Moment at support :**

If the edge support is integral with a column or beam, top reinforcement must be placed on this support in order to balance a moment at least equal to:

$$M = - 0,15 M_0$$

With,

$M_0$ : isostatic moment ( $M_0 = \frac{q \times l^2}{8}$ )

- **Moment at Intermediate Supports :**

The absolute value of the moment on the intermediate supports adjacent to the edge supports of a beam with more than two webs, in our case, is :

$$M_{\text{support}} = 0.5 \times M_0$$

- **Moment in span :**

These are determined from the following two conditions:

$$a) \quad M_t + \frac{M_w + M_e}{2} \geq \max \begin{cases} (1 + 0.3\alpha)M_0 \\ 1.05 M_0 \end{cases}$$

$$b) \quad M_t \geq \frac{1+0.3\alpha}{2} M_0 \quad \text{for an intermediate span}$$

$$M_t \geq \frac{1.2+0.3\alpha}{2} M_0 \quad \text{for an edge span}$$

$M_t$ : max between the two values.

Where:  $\alpha = \frac{q}{q+g}$  (degree of overload)

✓ **Ultimate limit state calculation**

We will calculate the reinforcement for a typical floor slab.

a) Calculation of beam loads

$$G = 5.52 \text{ kN/m}^2; Q = 1.5 \text{ kN/m}^2$$

$$P_u = (1.35 \times 5.52 + 1.5 \times 1.5) \times 0.65 = 6.30 \text{ kN/ml}$$

$$P_s = (5.52 + 1.5) \times 0.65 = 4.56 \text{ kN/ml}$$

$$\alpha = \frac{1.5}{1.5 + 5.52} = 0.2$$

$$1 + 0.3\alpha = 1.06$$

$$\frac{1+0.3\alpha}{2} = 0.53$$

$$\frac{1.2+0.3\alpha}{2} = 0.63$$

For:  $L_{\max} = 4.60\text{m}$

$$M_0 = \frac{6.30 \times 4.6^2}{8} = 16.67 \text{ kN.m}^2$$

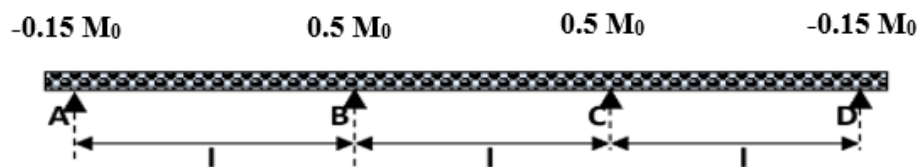

$$M_A = M_D = -0.15 M_0$$

- **Moment at intermediate support:**

$$M_B = M_C = 0.5 M_0 = 0.5 \times 16.67 = 8.33 \text{ kN.m}^2$$

- **Moment in the first span:**

$$M_1 + \frac{(0 + 0.5)M_0}{2} \geq \max \{1.06 M_0 ; 1.05M_0\} = 1.06 M_0 \rightarrow M_1 \geq 0.81 M_0$$

$$M_2 \geq \frac{1.2 + 0.3\alpha}{2} M_0 = 0.63 M_0$$

The value to remember is therefore:

$$M_{\text{span}} = \max \{M_1 ; M_2\} = 0.81 M_0$$

- **Moment in the central span:**

$$M_1 + \frac{(0.5 + 0.5)M_0}{2} \geq \max \{1.06 M_0 ; 1.05M_0\} = 1.06 M_0 \rightarrow M_1 \geq 0.56 M_0$$

$$M_2 \geq \frac{1+0.3\alpha}{2} M_0 = 0.53 M_0$$

The value to remember is therefore:

$$M_{\text{span}} = \max \{M_1; M_2\} = 0.56 M_0$$

The values are shown in the following figure.

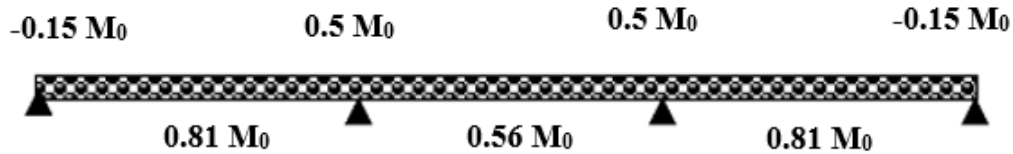

**Figure III-2: The flat-rate coefficient for the calculation of moment**

Therefore,  $M_{\text{span}} = 9.35 \text{ kN.m}^2$

- **Shear force :**

$$V = \frac{P_u \times l}{2} = \frac{6.30 \times 4.60}{2}$$

$$V = 14.5 \text{ kN}$$

**b) Reinforcement of joists**

After concreting, the cross-section of the beams becomes a T-section; the floor area assigned to each beam is a strip with a width of 65 cm.

The reinforcement is calculated for the floor joists on the current floor, which are subjected to the following loads:

$$M_{\text{span}} = 9.35 \text{ kN.m}^2$$

$$M_{\text{support}} = 8.33 \text{ kN.m}^2$$

$$V = 14.5 \text{ kN}$$

The geometrical characteristics of the joist are :

### Chapter III. Study of secondary elements

$$b = 65 \text{ cm}$$

$$b_0 = 10 \text{ cm}$$

$$h = 21 \text{ cm}$$

$$d = 18.9 \text{ cm}$$

$$d' = 2.1 \text{ cm}$$

$$h_0 = 5 \text{ cm}$$

$$b_1 = 27.5 \text{ cm}$$

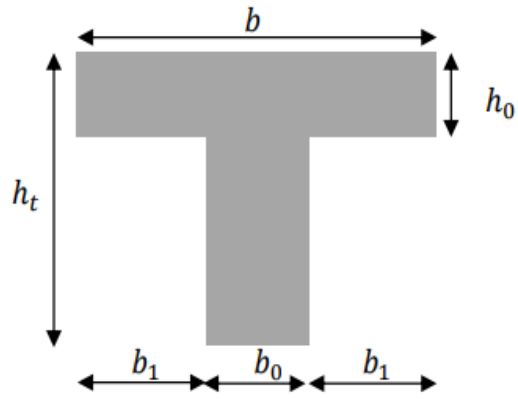

Figure III-3 : Cross-section of a joist

#### c) Longitudinal reinforcement

##### - In span :

The calculation is carried out according to the diagram for a tee section subjected to compound bending.

$$M_{tu} = f_{bu} \times b \times h_0 \left( d - \frac{h_0}{2} \right) = 14.17 \times 0.65 \times 0.05 \times 10^3 \times \left( 0.189 - \frac{0.05}{2} \right) = 75.52 \text{ kN.m}^2$$

So,  $M_{tu} > M_t = 9.35 \text{ kN.m}^2 \rightarrow$  The neutral axis is in the table, the calculation is made in simple bending on the rectangular section  $b \times h$  ( $65 \times 21$ )  $\text{cm}^2$

$$\mu = \frac{M_t}{bd^2 f_{bu}} = \frac{9.35}{0.62 \times (0.189 \times 0.9)^2 \times 14.17} = 0.03 < \mu_{ab} = 0.187$$

Pivot A ( $\epsilon_s = 10\text{‰}$ ) et  $A_{sc} = 0$

$$\alpha = 1.25(1 - \sqrt{1 - 2\mu}) = 1.25(1 - \sqrt{1 - 2(0.03)}) = 0.04$$

$$\epsilon_b = \frac{\alpha}{1 - \alpha} \epsilon_s = \frac{0.05}{1 - 0.05} 10 = 0.37 \text{ ‰}$$

$$Z = d(1 - 0.4\alpha) = 0.9 \times 0.21(1 - 0.4 \times 0.04) = 0.20 \text{ m.}$$

$$A_s = \frac{M_d}{Z \cdot \sigma_s} = \frac{9.35}{0.2 \times 434} = 1.20 \text{ cm}^2$$

##### - Condition of non-fragility:

$$A_{\min} \geq 0.23b \cdot d \frac{f_{t28}}{f_e} = 0.23 \times 0.65 \times 0.9 \times 0.21 \times \frac{2.1}{500} = 1.18 \text{ cm}^2$$

$$A_s = 1.20 \text{ cm}^2 > A_{\min} = 1.18 \text{ cm}^2 \rightarrow \text{Condition checked}$$

We adopt : **3HA10** = 2.36  $\text{cm}^2$

- **In intermediate support**

The moment is negative in support, so the compression table is in the tension zone, so the concrete is not included in the calculation. The T-section will be calculated as a rectangular section  $b_0 \times h$  (10×21) cm<sup>2</sup>

$$\mu = \frac{M_s}{bd^2f_{bu}} = \frac{8.33}{0.10 \times (0.189 \times 0.9)^2 \times 14.17} = 0.16 < \mu_{ab} = 0.187$$

pivot A (  $\epsilon_s = 10\text{‰}$  ) et  $A_{sc} = 0$

$$\alpha = 1.25(1 - \sqrt{1 - 2\mu}) = 1.25(1 - \sqrt{1 - 2(0.16)}) = 0.23$$

$$\epsilon_b = \frac{\alpha}{1-\alpha} \epsilon_s = \frac{0.23}{1-0.23} 10 = 2.92 \text{‰}$$

$$Z = d(1 - 0.4\alpha) = 0.9 \times 0.21(1 - 0.4 \times 0.23) = 0.17\text{m.}$$

$$A_s = \frac{M_a}{Z.\sigma_s} = \frac{8.33}{0.17 \times 434} = 1.12 \text{ cm}^2$$

- **Condition of non-fragility:**

$$A_{\min} \geq 0.23b.d \frac{f_{t28}}{f_e} = 0.23 \times 0.10 \times 0.9 \times 0.21 \times \frac{2.1}{500} = 0.20 \text{ cm}^2$$

$$A_s = 1.12 \text{ cm}^2 > A_{\min} = 0.20 \text{ cm}^2 \quad \rightarrow \quad \text{Condition checked}$$

We adopt **3HA10** = 2.36 cm<sup>2</sup>

**d) Shear force verification**

$$\tau_u = \frac{V_u}{b_0 \times d} \leq \bar{\tau}_u = \min (0.2f_{cj} / \gamma_b, 5\text{MPa}) = 3.33 \text{ MPa}$$

With,

$$\tau_u = \frac{14.50}{0.1 \times 0.9 \times 0.21} = 0.77 \text{ MPa.}$$

Therefore,  $\tau_u < \bar{\tau}_u \quad \rightarrow \quad \text{Condition checked}$

$\rightarrow$  There is no need for shear reinforcement.

The following table summarizes the results found for the ground floor (commercial) and the terrace floor.

**Table III-1: Results of longitudinal reinforcement in spans**

	$P_u$ [kN]	$M_0$ [kN.m <sup>2</sup> ]	$M_t$ [kN.m <sup>2</sup> ]	$A_s$ [cm <sup>2</sup> ]	$A_{NBC}$ [cm <sup>2</sup> ]	Choice of bars
<b>Ground level</b>	8.74	23.13	12.95	1.62	1.18	3HA10
<b>Typical floor</b>	6.3	16.67	9.33	1.2	1.18	3HA10
<b>Terrace floor</b>	6.66	17.62	9.90	1.23	1.18	3HA10

**Table III-2: Results of longitudinal reinforcement at supports**

	$P_u$ [kN]	$M_0$ [kN.m <sup>2</sup> ]	$M_t$ [kN.m <sup>2</sup> ]	$A_s$ [cm <sup>2</sup> ]	$A_{NBC}$ [cm <sup>2</sup> ]	Choice of bars
<b>Ground level</b>	8.74	23.13	11.56	1.62	0.2	3HA10
<b>Typical floor</b>	6.3	16.66	8.33	1.12	0.2	3HA10
<b>Terrace floor</b>	6.66	17.62	8.81	1.2	0.2	3HA10

**Table III-3: Verification of shear stress**

	$P_u$ [kN]	$V_u$ [kN]	$\tau_u$ [MPa]	$\bar{\tau}_u$ [MPa]	Condition
<b>Ground level</b>	8.74	20.1	1.06	3.33	Checked
<b>Typical floor</b>	6.3	14.5	0.77	3.33	Checked
<b>Current floor</b>	6.66	15.3	0.81	3.33	Checked

**e) Transversal reinforcement**

The diameter of the transverse reinforcement is given by :

$$\phi_t \geq \text{Min} \left( \frac{h}{35}; \phi_l; \frac{b}{10} \right) = \text{Min} \left( \frac{21}{35}; 10; \frac{10}{10} \right) = 6 \text{ mm}$$



We adopt **2HA8**  $\rightarrow A_t = 1.01 \text{ cm}^2$

✓ Spacing  $S_t$  :

The spacing of the transverse reinforcement must meet the following conditions according to BAEL91:

- $S_t \leq \min (0.9d; 40 \text{ cm} ) = 17 \text{ cm}$
- $S_t \leq \frac{A_t \cdot 0.8 \cdot f_e}{b (\tau_u - 0.3K f_{tj})} = \frac{0.57 \times 0.8 \times 500}{10 (0.77 - 0.3 \times 1 \times 2.1)} = 162 \text{ cm}$
- $S_t \leq \frac{f_e \times A_t}{0.4 \times b_0} = \frac{500 \times 0.57}{0.4 \times 0.10} = 71.25 \text{ cm}$

We adopt  $S_t = 15 \text{ cm}$

### f) Reinforcement details

The reinforcement diagram is shown in the following figure.

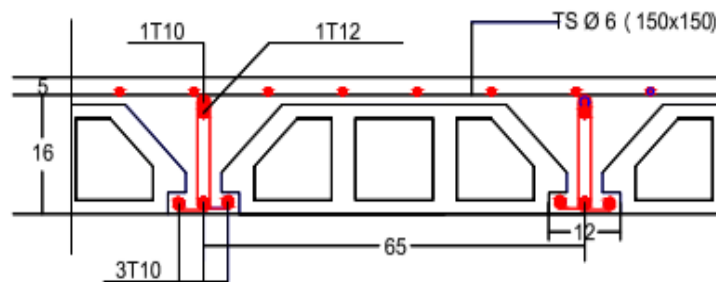

**Figure III-4: Reinforcement details of joists**

## III.2.2 Solid slab floor

Solid slab floors are used in balconies with a thickness of 15cm. These are modelled as uniformly loaded slabs embedded on three sides. BARES tables have been used to calculate the moments.

### a) Evaluation of loads

$$G = 6.63 \text{ kN/m}^2$$

### Chapter III. Study of secondary elements

$$Q = 3 \text{ kN/m}^2$$

$$q_u = 1.35G + 1.5Q = 1.35 \times 6.63 + 1.5 \times 3$$

$$q_u = 13.45 \text{ kN/m}^2$$

$$q_s = G + Q = 6.63 + 3$$

$$q_s = 9.63 \text{ kN/m}^2$$

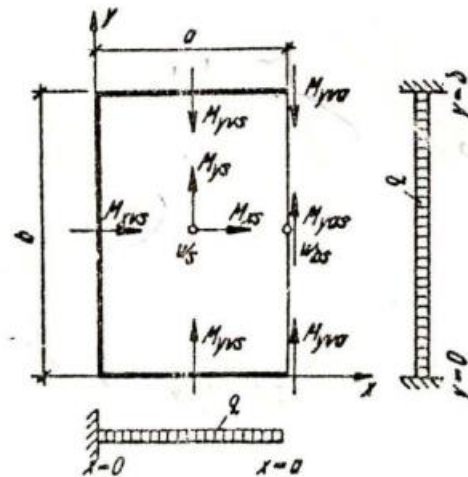

Figure III-5: Three-sided embedded panel

With,  $a = 1.45 \text{ m}$  and  $b = 2.15 \text{ m}$

$$Y = \frac{a}{b} = \frac{1.45}{2.15} = 0.80$$

$a, b$ : Dimensions of the slab.

$Y$ : Ratio of the sides of the slab.

According to the BARES table (Appendix C), we have:

**Table III-4: Results of moments calculations**

	Formula of the moment	Moment value at ULS [kN.m]	Moment value at ULS [kN.m]
$M_{xvs}$	$0.0865 qa^2$	2.45	1.75
$M_{xs}$	$0.0173 qa^2$	0.49	0.35
$M_{ys}$	$0.0247 qb^2$	1.54	1.10
$M_{yvs}$	$0.0561 qb^2$	3.49	2.50
$M_{yas}$	$0.0413 qb^2$	2.57	1.84
$M_{yva}$	$0.084 qb^2$	5.22	3.74

Where,  $q = q_u$  in ULS case and  $q_s$  in SLS case

### b) Ultimate limit state reinforcement

#### - In x direction :

$h = 15 \text{ cm}$ ,  $d = 0.9 \times (15) = 13.5 \text{ cm}$ ,  $f_{c28} = 25 \text{ MPa}$ ,  $f_{bu} = 14.17 \text{ MPa}$ ,  $f_{t28} = 2.1 \text{ MPa}$ ,

$f_e = 500 \text{ MPa}$

Using the simple bending diagram for rectangular sections (appendix A), we find:

$$\mu = \frac{M_{ax}}{bd^2f_{bu}} = \frac{2.45}{(0.135 \times 0.9)^2 \times 14.17} = 0.01 < \mu_{ab} = 0.187$$

pivot A ( $\epsilon_s = 10\text{‰}$ ) et  $A_{sc} = 0$

$$\alpha = 1.25(1 - \sqrt{1 - 2\mu}) = 1.25(1 - \sqrt{1 - 2(0.01)}) = 0.01$$

$$\epsilon_b = \frac{\alpha}{1-\alpha} \epsilon_s = \frac{0.01}{1-0.01} 10 = 0.12 \text{ ‰}$$

$$Z = d(1 - 0.4\alpha) = 0.9 \times 0.21(1 - 0.4 \times 0.01) = 0.13 \text{ m.}$$

$$A_s = \frac{M_a}{Z \cdot \sigma_s} = \frac{1.45}{0.13 \times 434} = 0.42 \text{ cm}^2$$

We adopt **5HA12/ml** =  $5.65 \text{ cm}^2$

Spacing:  $S_{max} = 100/5 = 20 < 33 \text{ cm}$

✓ **Verification:**

$$A_{\min} = \max \left\{ \frac{b \cdot h}{1000} ; 0.23 b \cdot d \frac{f_{t28}}{f_e} \right\} = \max \left\{ \frac{100 \times 15}{1000} ; 0.23 \times 1 \times 0.9 \times 0.15 \times \frac{2.1}{500} \right\} =$$

$$\max \{ 1.5 \text{ cm} ; 1.30 \text{ cm}^2 \} = 1.50 \text{ cm}^2$$

$$A_s = 5.65 \text{ cm}^2 > A_{\min} = 1.50 \text{ cm}^2 \quad \rightarrow \text{Condition checked.}$$

- **In y direction:**

✓ **In span :**

$$\mu = \frac{M_{ty}}{b d^2 f_{bu}} = \frac{1.53}{(0.135 \times 0.9)^2 14.17} = 0.01 < \mu_{ab} = 0.187$$

pivot A (  $\epsilon_s = 10\%$  ) et  $A_{sc} = 0$

$$\alpha = 1.25(1 - \sqrt{1 - 2\mu}) = 1.25(1 - \sqrt{1 - 2(0.01)}) = 0.01$$

$$\epsilon_b = \frac{\alpha}{1 - \alpha} \epsilon_s = \frac{0.01}{1 - 0.01} 10 = 0.08 \%$$

$$Z = d(1 - 0.4\alpha) = 0.9 \times 0.21(1 - 0.4 \times 0.01) = 0.13 \text{ m.}$$

$$A_s = \frac{M_a}{Z \cdot \sigma_s} = \frac{1.53}{0.13 \times 434} = 0.30 \text{ cm}^2$$

We adopt **5HA12/ml** = 5.65 cm<sup>2</sup>

Spacing:  $S_{\max} = 100 / 5 = 20 < 33 \text{ cm}$

✓ **Verification:**

$$A_{\min} = \max \left\{ \frac{b \cdot h}{1000} ; 0.23 b \cdot d \frac{f_{t28}}{f_e} \right\} = \max \left\{ \frac{100 \times 15}{1000} ; 0.23 \times 1 \times 0.9 \times 0.15 \times \frac{2.1}{500} \right\} =$$

$$\max \{ 1.5 \text{ cm} ; 1.30 \text{ cm}^2 \} = 1.50 \text{ cm}^2$$

$$A_s = 5.65 \text{ cm}^2 > A_{\min} = 1.50 \text{ cm}^2 \quad \rightarrow \text{Condition checked.}$$

✓ **In support:**

$$\mu = \frac{M_{ay}}{b d^2 f_{bu}} = \frac{5.22}{(0.135 \times 0.9)^2 14.17} = 0.02 < \mu_{ab} = 0.187$$

pivot A (  $\epsilon_s = 10\%$  ) et  $A_{sc} = 0$

$$\alpha = 1.25(1 - \sqrt{1 - 2\mu}) = 1.25(1 - \sqrt{1 - 2(0.02)}) = 0.01$$

$$\varepsilon_b = \frac{\alpha}{1-\alpha} \varepsilon_s = \frac{0.02}{1-0.02} 10 = 0.26 \text{ ‰}$$

$$Z = d(1 - 0.4\alpha) = 0.9 \times 0.21(1 - 0.4 \times 0.02) = 0.13 \text{ m.}$$

$$A_s = \frac{M_a}{Z \cdot \sigma_s} = \frac{5.22}{0.13 \times 434} = 1.00 \text{ cm}^2$$

We adopt **5HA12/ml** = 5.65 cm<sup>2</sup>

Spacing:  $S_{\max} = 100/5 = 20 < 33 \text{ cm}$

✓ **Verification:**

$$A_{\min} = \max \left\{ \frac{b \cdot h}{1000} ; 0.23 b \cdot d \frac{f_{t28}}{f_e} \right\} = \max \left\{ \frac{100 \times 15}{1000} ; 0.23 \times 1 \times 0.9 \times 0.15 \times \frac{2.1}{500} \right\} =$$

$$\max \{ 1.5 \text{ cm} ; 1.30 \text{ cm}^2 \} = 1.50 \text{ cm}^2$$

$$A_s = 5.65 \text{ cm}^2 > A_{\min} = 1.50 \text{ cm}^2 \quad \rightarrow \quad \text{Condition checked}$$

**c) Condition of non-fragility**

The minimum steel rate must meet the following condition:

$$\rho_x \geq \rho_0 \frac{3 - \frac{a}{b}}{2}$$

$$\rho_0 \geq 0.23 \frac{f_{tj}}{f_e} \quad \rightarrow \quad \rho_0 \geq 0.23 \frac{2.1}{500} = 0.97 \%$$

$$\rho_x \geq 0.97 \% \frac{3 - \frac{1.45}{2.15}}{2} = 0.11 \%$$

$$\rho_y \geq \frac{A(y)}{b \cdot d} = \frac{2.51}{100 \times 13.50} = 0.19 \%$$

Therefore,  $\rho_y > \rho_x \quad \rightarrow \quad \text{Condition checked}$

**d) Shear stress verification**

$$V_u = \frac{q_u \times l_x}{2} = \frac{13.45 \times 1.45}{2} = 9.75 \text{ kN}$$

$$\tau_u = \frac{V_u}{b_0 \times d} \leq \bar{\tau}_u = \min (0.2f_{cj} / \gamma_b , 5 \text{ MPa} ) = 3.33 \text{ MPa}$$

With,

$$\tau_u = \frac{9.75}{1 \times 0.135} = 0.07 \text{ MPa.}$$

Therefore,  $\tau_u < \overline{\tau_u} \rightarrow$  Condition checked

**e) Reinforcement details:**

The reinforcement diagram is shown in the following figure.

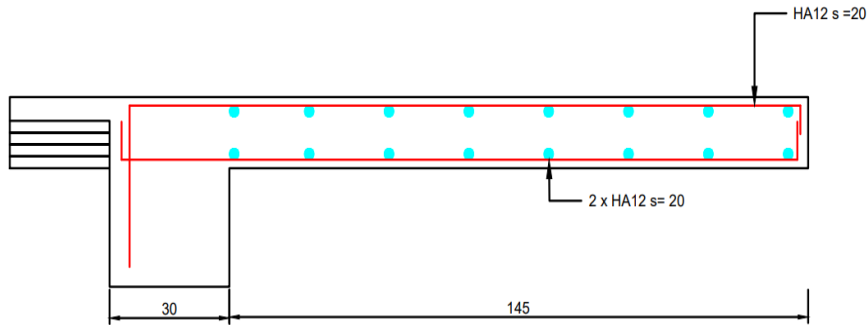

**Figure III-6: Reinforcement details of the Balcony**

**III.3 Study of the parapet**

The parapet is a non-structural element in reinforced concrete equivalent to a 100 cm console, embedded in the terrace floor, subject to a normal load due to its own weight and a moment at embedment due to an exposure surcharge of 1 kN/ml applied to its end. Cracking is considered prejudicial because the parapet is subject to weathering.

**a) Load assesement**

- ✓ Permanent load (proper weight):  $G = 2.57 \text{ kN/ml}$
- ✓ Operating load:  $q = 1 \text{ kN/ml}$

**b) Earthquake action**

According to article 6.2.3 of RPA99/2003, the horizontal force acting on the element is given as follows:

$$F_p = 4A C_p W_p$$

$A = 0.20$

$C_p$  : horizontal force factor (table 6.1 RPA99/2003)

$\rightarrow C_p = 0.8$

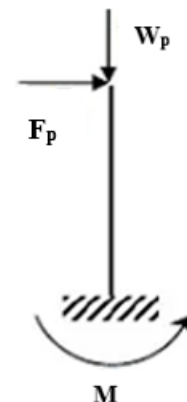

### Chapter III. Study of secondary elements

$W_p = 2.57 \text{ kN/ml}$  (parapet weight)

$$F_p = 4 \times 0.20 \times 0.8 \times 2.57 = 1.64 \text{ kN /ml}$$

The condition  $F_p < 1.5 q$  is not verified, so we take:

$$Q = \max (q ; F_p) = \max (1.00 ; 1.64 ) = 1.64 \text{ KN/ml}$$

#### c) Evaluation of loads

The following table summarizes the results of loads evaluation in ultimate and service limit state.

**Table III-5: Loads evaluation**

Combination of actions			
Ultimate limit state	Ultimate permanent load	$N_u = 1.35W_p$	3.4695 kN/ml
	Ultimate operating load	$Q_u = 1.5Q$	2.46 kN/ml
	Embedding moment	$M_u = Q_u .h$	1.47 kN.m
Service limit state	Ultimate dead load	$N_u = W_p$	2.57 kN/ml
	Ultimate operating load	$Q_s = Q$	1.64 kN/ml
	Embedding moment	$M_s = Q_s.h$	0.98 Kn.m

#### d) Calculation of the reinforcement at ULS

The section of the parapet is (100×10) cm. The longitudinal reinforcement is calculated in compound bending as follows.

$$f_{c28} = 25\text{MPa}, f_e = 500\text{MPa}, f_{bu} = 14.17\text{MPa}, f_{t28} = 2.1\text{MPa}, \sigma_s = 434\text{MPa}.$$

✓ Eccentricity:

$$e = e_0 + e_a$$

With,

$$e_0 = \frac{M_u}{N_u} = \frac{1.47}{3.4695} = 0.42 \text{ m}$$

$$e_a = \max ( 2\text{cm} ; \frac{h}{250} = \frac{60}{250} = 0.24\text{cm} ) = 2 \text{ cm}$$

### Chapter III. Study of secondary elements

---

$$e = 0.26 + 0.02 = 0.44 \text{ m}$$

The center of pressure is outside the section, the section is partially compressed.

✓ Correlation coefficient  $\mathbf{Y}_n$  :

$$\frac{e_0}{h} = \frac{0.42}{0.10} = 4.25 > 1 \quad \rightarrow \quad \mathbf{Y}_n = 1 + 0.2 \left(\frac{\lambda}{35}\right)^2 \left(\frac{h}{e_0}\right)$$

$$\text{We have, } L_f = 0.7l = 0.7 \times 0.6 = 0.42 \text{ m}$$

$$\lambda = \frac{L_f}{i} = \sqrt{12} \frac{L_f}{b} = \frac{\sqrt{12} \cdot 0.42}{1} = 1.45 < 50$$

$$\text{Therefore, } \mathbf{Y}_n = 1 + 0.2 \left(\frac{1.45}{35}\right)^2 \left(\frac{0.10}{0.26}\right) = 1.00$$

✓ Correction of solicitations :

$$N_u = \mathbf{Y}_n \cdot N_{u0} = 1.00 \times 3.4695 = 3.4695$$

$$M_u = \mathbf{Y}_n \cdot M_{u0} + N_u \cdot e_a = 1.00 \times 0.9 + 3.4695 \times 0.02 = 1.54 \text{ kN.m}$$

As the section is partially compressed, the calculation is reduced to a simple bending calculation with a moment calculated as follows:

$$M_{uA} = N_u \times e_{As}$$

Where  $e_{As}$  is the distance between the point of application of the centre of pressure and the centre of gravity of the tensioned reinforcement.

$$e_{As} = 0.46 \text{ m}$$

$$M_{uA} = 3.4695 \times 0.46 = 1.6 \text{ kN.m}$$

$$\mu = \frac{M_{uA}}{bd^2 f_{bu}} = \frac{1.6}{1 \times (0.1 \times 0.9)^2 \cdot 14.17} = 0.01 < \mu_{ab} = 0.187$$

pivot A ( $\epsilon_s = 10\text{‰}$  ;  $\epsilon_b = 3.5\text{‰}$ ) et  $A_{sc} = 0$

$$\alpha = 1.25(1 - \sqrt{1 - 2\mu}) = 1.25(1 - \sqrt{1 - 2(0.01)}) = 0.01$$

$$\epsilon_b = \frac{\alpha}{1 - \alpha} \epsilon_s = \frac{0.01}{1 - 0.01} 10 = 1.4\text{‰}$$



$$Z = d(1 - 0.4\alpha) = 0.9 \times 0.1(1 - 0.4 \times 0.01) = 0.09\text{m}$$

$$A_s = \frac{M_{uA}}{Z \cdot \sigma_s} = \frac{1.6}{0.09 \times 434} = 0.40 \text{ cm}^2$$

We use **welded wire mesh  $\phi 6$**  mm with a 10 cm grid.

✓ Spacing :

$$S_{\text{tmax}} = \frac{100}{4} = 25\text{cm} < 33\text{cm}$$

#### e) Condition of non-fragility

$$A_{\text{min}} \geq 0.23b.d \frac{f_{t28}}{f_e} = 0.23 \times 1 \times 0.9 \times 0.1 \times \frac{2.1}{500} = 0.87\text{cm}^2$$

$$A_s = 2.8 \text{ cm}^2 > A_{\text{min}} = 0.87\text{cm}^2 \rightarrow \text{condition checked}$$

#### f) Shear verification

The shear stress in concrete is given by the following formula, taking into account cracking deemed damaging:

$$\bar{\tau}_u = \min (0.15f_{cj} / \gamma_b, 4\text{MPa}) = 2.75 \text{ MPa}$$

Where,

$$\tau_u = \frac{2.46}{0.1 \times 0.9 \times 1} = 0.027 \text{ MPa.}$$

Therefore,  $\tau_u < \bar{\tau}_u \rightarrow$  Condition checked

### III.4 Study of stairs

The determination of the reinforcement of stairs is based on the determination of the stresses to which they are subjected.

In our case, the staircase consists of three flights, two of which are identical, with two intermediate landings.

### III.4.1 Study of the flight I

The figure below shows flight I of our staircase.

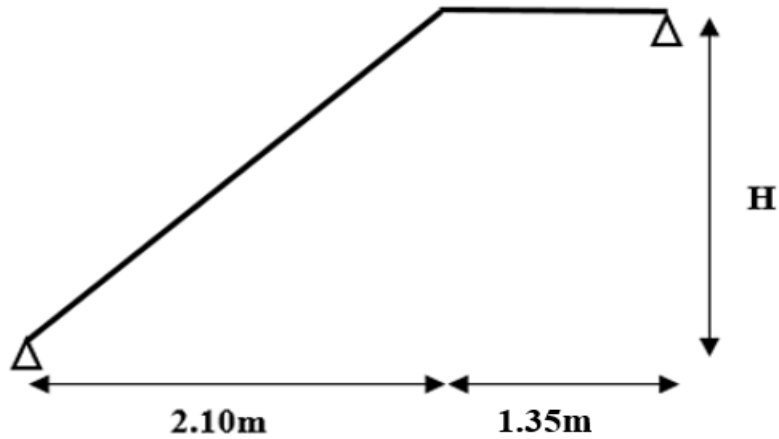

Figure III-7: Static model of flight I

#### a) Loads evaluation

Load evaluation is summarized in the following table.

Table III-6: Combination of action on the stairs

	Length [m]	G [kN/m <sup>2</sup> ]	Q [kN/m <sup>2</sup> ]	Q <sub>u</sub> ULU [kN/m <sup>2</sup> ]	Q <sub>s</sub> ELS [kN/m <sup>2</sup> ]
<b>Landing</b>	1.35	5.49	2.5	11.16	7.99
<b>Flight of stairs</b>	2.10	7.52	2.5	13.9	10.02

The following figure shows the forces applied to stairs at ultimate limit state.

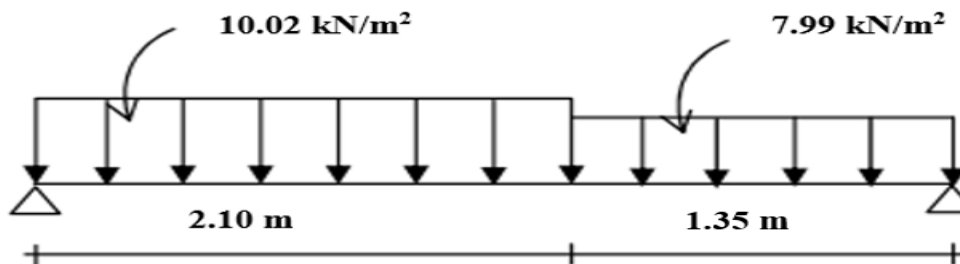

Figure III-8: Diagram of forces applied to staircases at ULU

#### b) Equivalent load

$$Q_e = \sum q_i \times L_i / \sum L_i$$

$$Q_e = \frac{13.9 \times 2.10 + 11.16 \times 1.35}{1.35 + 2.10} \rightarrow Q_e = 12.83 \text{ kN/m}$$

#### c) Reaction calculation

$$\sum F/y = 0 \rightarrow R_a + R_b - Q_e \cdot l = 0 \rightarrow R_a + R_b = 44.26 \text{ kN}$$

$$\sum M/A = 0 \rightarrow -R_b + \frac{Q_e \cdot l}{2} = 0$$

$$R_b = 22.13 \text{ kN} \quad \text{and} \quad R_a = 22.13 \text{ kN}$$

#### d) Calculation of shear force and bending moment

Using the section method :

$$T_x = Q_e \cdot x - R_a$$

$$T_x = 0 \rightarrow x = 22.13/12.83 = 1.73 \text{ m}$$

$$M_{\max} = R_a \cdot x + \frac{Q_e \cdot x^2}{2} = 22.13 \times 1.73 + \frac{12.83 \times 1.73^2}{2}$$

We found:

$$M_{\max} = 57.26 \text{ kN.m}$$

$$T_{\max} = 22.13 \text{ kN}$$

#### e) Calculation of the ultimate moment

- **Moment in span:**  $M = 0.85M_0 = 0.85 \times 57.26$

$$M = 48.67 \text{ kN.m}$$

- **Moment at support :**  $M = 0.2M_0 = 0.2 \times 57.26$

$$M = 11.45 \text{ kN.m}$$

#### f) Calculation of longitudinal reinforcement

Stair are calculated in simple bending, we consider the section as a rectangular section of 1m length and 15cm thickness, and the characteristics are as follow:

### Chapter III. Study of secondary elements

---

$h = 15\text{cm}$ ;  $b = 100\text{cm}$ ;  $d = 13.5\text{cm}$ ;  $f_{c28} = 25\text{MPa}$ ;  $f_e = 500\text{MPa}$ ;  $f_{bu} = 14.17\text{MPa}$ ;  $f_{t28} = 2.1\text{MPa}$ ;  
 $\sigma_s = 434\text{MPa}$ .

✓ **In span :**

$$\mu = \frac{M_u}{bd^2f_{bu}} = \frac{48.67}{1 \times (0.15 \times 0.9)^2 \times 14.17} = 0.188 > \mu_{ab} = 0.187$$

Pivot B ( $\epsilon_s = 2.17\text{‰}$ ,  $\epsilon_b = 3.5\text{‰}$ )  $A_{sc} = 0$

$$\alpha_1 = \frac{7}{7 + 2\epsilon_s} = 0.61$$

$$\mu_1 = 0.8 \alpha_1 (1 - 0.4 \alpha_1) = 0.370 > 0.222 \rightarrow A_{sc} = 0$$

$$\alpha = 1.25(1 - \sqrt{1 - 2\mu}) = 1.25(1 - \sqrt{1 - 2(0.188)}) = 0.263$$

$$Z = d(1 - 0.4\alpha) = 0.9 \times 0.15(1 - 0.4 \times 0.263) = 0.12 \text{ m}$$

$$A_s = \frac{M_u}{Z \cdot \sigma_s} = \frac{48.67}{0.12 \times 434} = 8.62 \text{ cm}^2$$

We adopt **8HA12/ml** =  $9.05 \text{ cm}^2$

✓ **Spacing :**

$$S_{tmax} = \frac{100}{7} = 14.3 \text{ cm} < 33 \text{ cm}$$

**g) Condition of non-fragility**

$$A_{min} = \max \left\{ \frac{b \cdot h}{1000} ; 0.23b \cdot d \frac{f_{t28}}{f_e} \right\} = \max \left\{ \frac{100 \times 15}{1000} ; 0.23 \times 1 \times 0.9 \times 0.15 \times \frac{2.1}{500} \right\} =$$

$$\max \{ 1.5 \text{ cm} ; 1.30 \text{ cm}^2 \} = 1.50 \text{ cm}^2$$

$$A_s = 8.62 \text{ cm}^2 > A_{min} = 1.50 \text{ cm}^2$$

- **In support :**

$$\mu = \frac{M_u}{bd^2f_{bu}} = \frac{11.45}{1 \times (0.15 \times 0.9)^2 \times 14.17} = 0.04 < \mu_{ab} = 0.187$$

pivot A ( $\epsilon_s = 10\text{‰}$ ;  $\epsilon_b = 3.5\text{‰}$ ) et  $A_{sc} = 0$

$$\alpha = 1.25(1 - \sqrt{1 - 2\mu}) = 1.25(1 - \sqrt{1 - 2(0.04)}) = 0.05$$

$$\epsilon_b = \frac{\alpha}{1 - \alpha} \epsilon_s = \frac{0.05}{1 - 0.05} 10 = 0.60 \text{ ‰}$$

### Chapter III. Study of secondary elements

---

$$Z = d(1 - 0.4\alpha) = 0.9 \times 0.1(1 - 0.4 \times 0.05) = 0.13 \text{ m}$$

$$A_s = \frac{M_u}{Z \cdot \sigma_s} = \frac{11.45}{0.13 \times 434} = 2.00 \text{ cm}^2$$

We adopt **6HA12/ml** = 6.79 cm<sup>2</sup>

✓ **Spacing :**

$$S_{\text{tmax}} = \frac{100}{6} = 16.6 \text{ cm} < 33 \text{ cm}$$

**h) Condition of non-fragility**

$$A_{\text{min}} = \max \left\{ \frac{b \cdot h}{1000} ; 0.23 b \cdot d \frac{f_{t28}}{f_e} \right\} = \max \left\{ \frac{100 \times 15}{1000} ; 0.23 \times 1 \times 0.9 \times 0.15 \times \frac{2.1}{500} \right\} =$$

$$\max \{ 1.5 \text{ cm} ; 1.30 \text{ cm}^2 \} = 1.50 \text{ cm}^2$$

$$A_s = 2 \text{ cm}^2 > A_{\text{min}} = 1.50 \text{ cm}^2$$

**i) Shear stress verification**

$$\tau_u = \frac{T_{\text{max}}}{b \cdot d} = \frac{22.13 \times 10^{-3}}{1 \times 0.135}$$

$$\tau_u = 0.2 \text{ MPa.}$$

$$\text{Verification: } \tau_u \leq 0.05 f_{c28}$$

$$\text{With, } 0.05 f_{c28} = 1.25 \text{ MPa}$$

$$\tau_u = 0.2 \text{ MPa} \leq 0.05 f_{c28} = 1.25 \text{ MPa} \rightarrow \text{Condition checked}$$

**j) Distribution reinforcement**

$$A_r = \frac{A_s}{4} = \frac{8.62}{4} = 2.15 \text{ cm}^2$$

We adopt **4HA10/ml** = 3.14 cm

k) Reinforcement details :

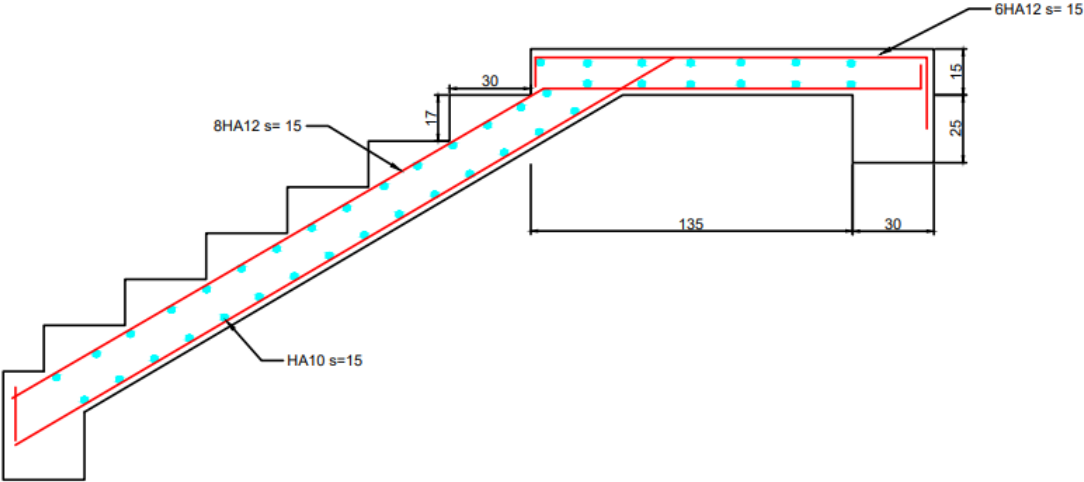

Figure III-9: Reinforcement details of flight I

III.5 Conclusion

In this chapter, we have carried out the calculations for the secondary elements of our structure, namely the body floor, the balcony, the stairs and the parapet. These elements play a crucial role in the stability and durability of the construction.

# **Chapter IV**

## **Dynamic Study**

### **IV.1 Introduction**

Seismic excitation generates forces in the structure that can lead to sudden collapse. It is necessary to study the response of the structure under this action in order to guarantee a certain level of protection for the building in the event of an earthquake, and to avoid as much as possible the damage that could be caused by this phenomenon.

### **IV.2 Objective of the dynamic study**

The initial aim of the dynamic study of a structure is to identify its own dynamic characteristics and to measure the elements of resistance, in order to obtain satisfactory safety for the structure as a whole during vibrations.

### **IV.3 Mathematical modelling**

Modelling consists of finding a simplified model that is as close as possible to the behavior of a real structure. This model represents a physical problem with an infinite number of degrees of freedom (DDL), whereas a model with a finite number of degrees of freedom (DDL) is reduced.

Given the complexity and difficulty of a manual calculation of internal forces, we use a calculation software called "ETABS" for modelling.

### **IV.4 Presentation of the ETABS software**

ETABS is an engineering software package for the analysis and design of multi-story buildings.

Modelling tools and models, code-based load prescriptions, analysis methods and solution techniques are all coordinated with the grid geometry specific to this category of structure. ETABS is used to evaluate systems under statics or dynamics conditions. For a sophisticated assessment of seismic performance, modal and direct time integration analyses can be coupled with P-Delta and large displacement effects. Non-linear links and hinges can capture the non-linearity of materials in monotonic or hysteretic behaviour.



## IV.5 Choice of the calculation method

The Algerian Paraseismic Rules (RPA99/2003) state that three methods of calculation can be used to determine the seismic forces, with the choice depending on the kind of structure and the dynamic character of the excitation:

- Equivalent statistical method.
- Modal spectral analysis method.
- Dynamic analysis method using accelerograms.

In our case, the equivalent static method is not applicable, as the structure does not meet all the conditions of article 4.1.2 of RPA99/2003: R+5 building with storey height  $h_{total} = 18.36m > 17m$  in zone IIb.

The "dynamic method" of spectral modal analysis is the approach that has to be taken.

## IV.6 Modal spectral analysis method

### IV.6.1 Principle

Modal analysis is used to determine the natural free vibration modes of the structure and their nature, and to understand the behavior of the building in the presence of dynamic loads such as seismic forces.

This method is used in all cases, and in particular where the equivalent static method is not permitted, in accordance with RPA99/2003.

### IV.6.2 Response spectrum

According to RPA99/2003, the seismic action is represented by the following calculation spectrum:

$$\frac{S_a}{g} = \begin{cases} 1.25A \left[ 1 + \frac{T}{T_1} (2.5\eta \frac{Q}{R} - 1) \right] & 0 \leq T \leq T_1 \\ 2.5\eta (1.25A) \left( \frac{Q}{R} \right) & T_1 \leq T \leq T_2 \\ 2.5\eta (1.25A) \left( \frac{Q}{R} \right) \left( \frac{T_2}{T} \right)^{2/3} & T_2 \leq T \leq 3.0s \\ 2.5\eta (1.25A) \left( \frac{T_2}{3} \right)^{2/3} \left( \frac{3}{T} \right)^{5/3} \left( \frac{Q}{R} \right) & T > 3.0s \end{cases}$$

With,

A: zone acceleration coefficient

$\eta$  : damping correction factor (when damping is different from 5%)

$$\eta = \sqrt{7/(2 + \xi)} \geq 0.7$$

$\xi$  : critical damping percentage (table 4.2 of RPA99/2003).

R: behavior coefficient of the structure (table 4.2 of RPA99/2003).

$T_1, T_2$ : characteristic periods associated with the site category (table 4.7 of RPA99/2003).

Q: quality factor, its value is determined by the following formula:

$$Q = 1 + \sum_1^6 Pq$$

$P_q$ : the penalty to be applied depending on whether the quality requirement "q" is satisfied or not (table 4.4 of RPA99/2003).

The following table summarizes the values used to calculate the response spectrum of our structure.

**Table IV-1: Values of each factor**

<b>Factor</b>	<b>Value</b>	<b>Unit</b>	<b>Justification</b>
<b>A</b>	0.20	/	Zone IIb, group 2
<b><math>\xi</math></b>	10	%	Reinforced concrete wall
<b><math>\eta</math></b>	0.763	/	$\xi \neq 5\% : \eta = \sqrt{7/(2 + \xi)}$
<b>R</b>	3.5	/	Shear walls
<b><math>T_1</math></b>	0.15	Second	Site S3
<b><math>T_2</math></b>	0.50	Second	
<b>Q</b>	1.20	/	$1 + (0+0 + 0.05 + 0 + 0.05 + 0.10)$

The figure IV-1 shows the spectral response graph.

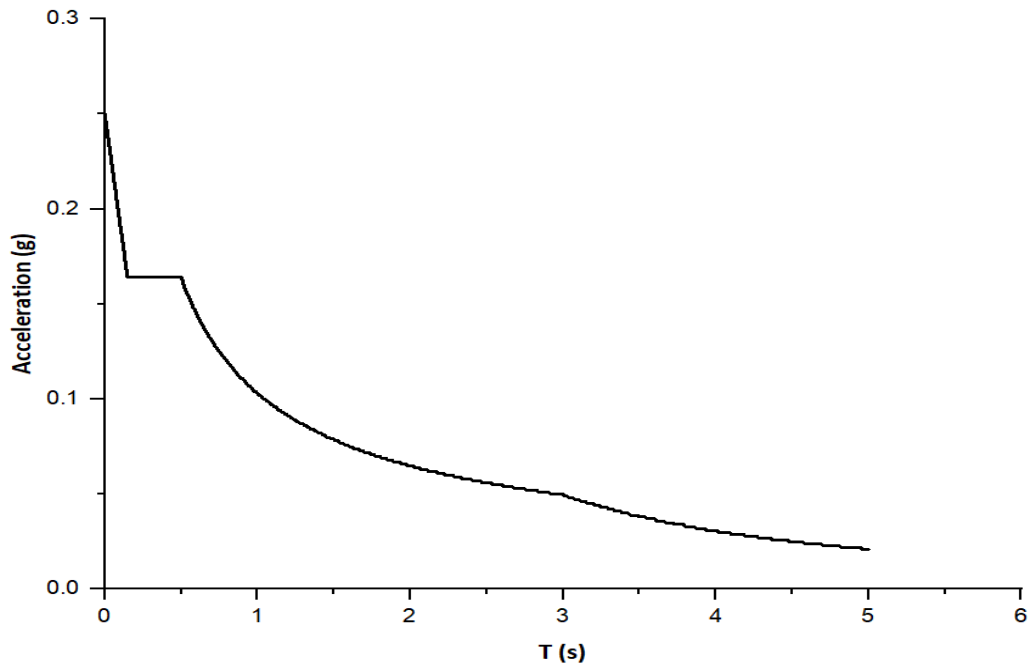

**Figure IV-1: Spectral response**

### **IV.7 Dynamic analysis**

#### **IV.7.1 Structural modeling**

A three-dimensional model implanted in the base, with two horizontal translations and one rotation along the vertical axis, will represent the structure in question. The masses are concentrated around the center of mass of the floor.

#### **IV.7.2 Modelling steps**

To model our building we will consider the following steps:

Step 1:

Introduction of the model geometry (position of junctions, connectivity of elements).

Step 2:

Specification of the properties of the elements of the structure to be modelled (definition and allocation of the cross-sections of the elements and materials).

Step 3:

Specification of boundary conditions (supports, embedding...) for the structure to be modelled.

Step 4:

Definition of the loads applied to the structure to be modelled (vertical loads and response spectrum corresponding to the horizontal load).

Step 5:

Definition and allocation of load combinations.

Step 6:

Execution and analysis of the results by choosing the number of modes to be taken into consideration

Step 7:

The results files are used to check the structural elements (reduced normal force, period, seismic force....) and to calculate the reinforcement.

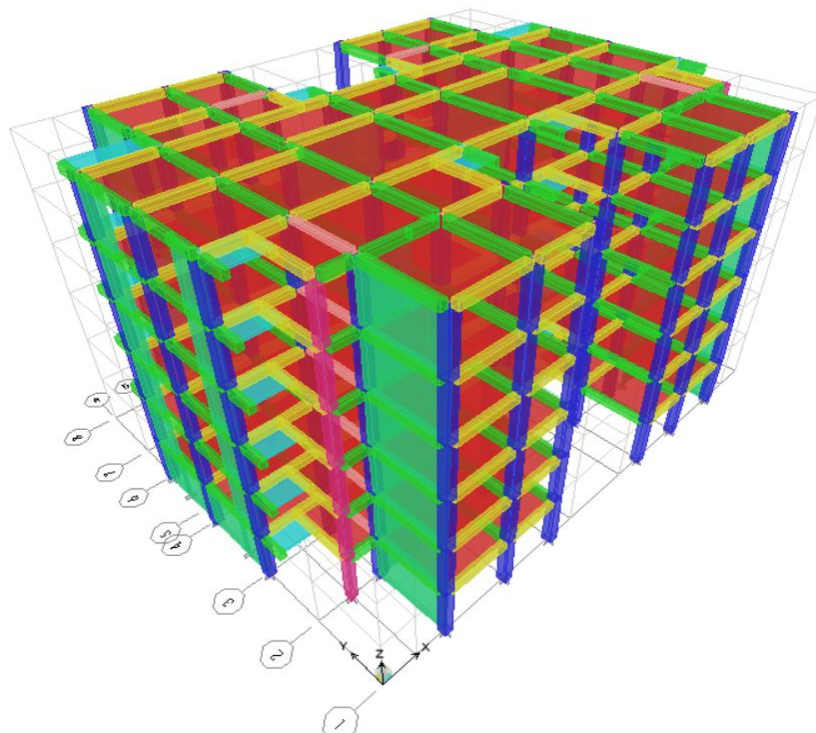

**Figure IV-2: Structural modeling**

### IV.7.3 Vibration periods and mass participation

The following table shows the vibration periods and the mass participation rate in the X and Y directions.

**Table IV-2: Vibration periods and the mass participation rate**

Mode	Period [s]	Modal mass UX [%]	Modal mass UY [%]	Cumulative mass UX [%]	Cumulative mass UY [%]
1	0.313	64.963	0.0003	64.963	0.0003
2	0.279	0.003	65.451	64.966	65.451
3	0.265	2.490	0.0345	67.456	65.486
4	0.075	15.656	0	83.118	65.486
5	0.066	0.0002	18.408	83.115	83.894
6	0.062	1.709	0.001	84.825	83.895
7	0.036	5.824	0	90.649	83.895
8	0.031	0.0001	7.144	90.649	91.039
9	0.029	0.548	0.0002	91.196	91.039
10	0.023	3.622	0	94.820	91.039
11	0.021	0.0001	4.538	94.820	95.577
12	0.019	0	0.0001	94.820	95.577

The dynamic analysis of the structure led to:

- ✓ The first mode is a translation mode parallel to X-X: modal participation in the X direction is predominant (UX=64.96 %).
- ✓ The second mode is a translation mode parallel to Y-Y: modal participation in the Y direction is predominant (UY=65.45 %).
- ✓ The third mode is a rotation mode.
- ✓ The fundamental period of vibration:  $T = 0.31s$

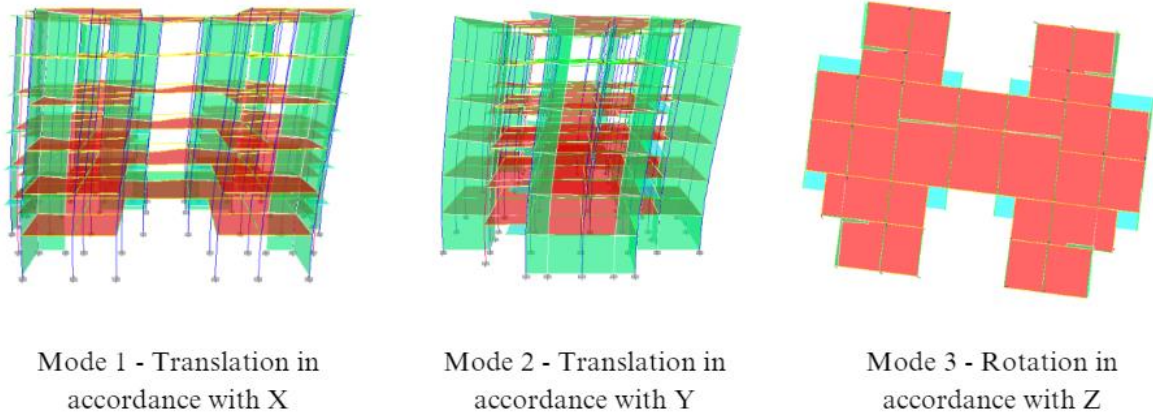

Figure IV-3: Mode shapes

#### IV.7.4 Calculation of the total seismic force

According to article 4.2.3 of RPA99/2003, the total seismic force  $V$ , applied to the base of the structure, must be calculated successively in orthogonal and horizontal directions according to the following formula:

$$V = \frac{A \cdot D \cdot Q}{R} W$$

With,

$A$  : zone acceleration coefficient.  $\rightarrow A = 0.25$

$D$  : average dynamic amplification factor.

$$D = \begin{cases} 2.5\eta & 0 \leq T \leq T_2 \\ 2.5 \eta \left(\frac{T_2}{T}\right)^{2/3} & T_2 \leq T \leq 3.0s \\ 2.5 \eta \left(\frac{T_2}{3}\right)^{2/3} \left(\frac{3}{T}\right)^{5/3} & T > 3.0s \end{cases}$$

$\eta$ : damping correction factor.

$T_2$ : characteristic period, associated with the site category.  $\rightarrow T_2 = 0.50$  s

$R$ : behaviour coefficient.  $\rightarrow R = 3.5$

$Q$ : quality factor.  $\rightarrow Q = 1.20$

$W$ : total weight of the structure

According to formula (4.5) of RPA99/2003:

$$W = \sum_{i=1}^n W_i$$

$$W_i = W_{Gi} + \beta W_{Qi}$$

$W_{Gi}$ : weight due to permanent loads and any fixed equipment attached to the structure.

$W_{Qi}$ : wperating loads.

$\beta$ : A weighting coefficient based on the nature and duration of the operating costs.

In our case, the structure is of the residential type, so  $\beta = 0.20$ .

The total weight of the structure was calculated using ETABS software, and the value found is:

$$W = 28041.70 \text{ kN}$$

### - Estimation of the fundamental period of the structure :

According to RPA99/2003, the value of the fundamental period (T) can be estimated from the empirical formulae to be used according to the case.

$$T = C_T h_N^{3/4}$$

$h_N$ : height measured in metres from the base of the structure to the last level (N)

In our case,  $h_N = 18.36\text{m}$

$C_T$ : coefficient depending on the bracing system and the type of infill given in table 4.6 of RPA99/2003.  $\rightarrow C_T = 0.05$

Therefore,

$$T = 0.44\text{s}$$

As this is the 4<sup>th</sup> case, according to RPA99/2003 we can also use the formula :

$$T = 0.09h_N / \sqrt{D}$$

D: Dimension of the building measured at its base in the direction of calculation considered.

$$x \text{ - Direction: } D_x = 27.50 \text{ m} \quad \rightarrow \quad T_x = 0.31\text{s}$$

$$y \text{ - Direction: } D_y = 21.80 \text{ m} \quad \rightarrow \quad T_y = 0.35\text{s}$$

In this case, the smaller of the two values given respectively by the 02 previous formula should be used for each direction under consideration.

The fundamental static period is therefore:

$$T_{sx} = \min (0.44s; 0.31s) \rightarrow T_{sx} = 0.31s$$

$$T_{sy} = \min (0.44s; 0.35s) \rightarrow T_{sy} = 0.35s$$

Moreover, the fundamental static period plus 30% is:

$$1.3T_{sx} = 1.3 \times 0.31 \rightarrow 1.3T_{sx} = 0.40 \text{ s}$$

$$1.3T_{sy} = 1.3 \times 0.31 \rightarrow 1.3T_{sy} = 0.45 \text{ s}$$

$$0 \leq T \leq 0.50 \text{ s} \rightarrow D = 2.5\eta$$

We have,  $\eta = 0.76$

Thus,  $D = 1.9$

✓ The value of the shear force in both directions:

$$V_x = \frac{0.2 \times 1.90 \times 1.20}{3.5} \times 28041.70 = 3653.43 \text{ kN}$$

$$V_y = \frac{0.2 \times 1.90 \times 1.20}{3.5} \times 28041.70 = 3653.43 \text{ kN}$$

$$0.8 V_x = 2922.74 \text{ kN}$$

$$0.8 V_y = 2922.74 \text{ kN}$$

### IV.7.5 Calculations Verification

#### IV.7.5.1 Verification of the resultant of the seismic forces

The resultant of the seismic forces at the base obtained by combining the modal values must not be less than 80% of the resultant of the seismic forces determined by the equivalent static method for a value of the fundamental period given by the empirical formula, according to article 4.3.6 of RPA99/2003.

The following table summarizes the verifications of the resultant of the seismic forces



## Chapter IV. Dynamic study

**Table IV-3: The verifications of the resultant of the seismic forces in both directions**

Seismic force	$V_{static}$ [kN]	$0.8V_{static}$ [kN]	$V_{dynamic}$	Observation
Direction-X	3653.43	2922.74	3061.36	Condition verified
Direction-Y	3653.43	2922.74	3105.33	Condition verified

### IV.7.5.2 Verification of the reduced normal force

According to article 7.1.3.3 of RPA99/2003, the reduced normal force is limited by the following condition to avoid crushing of the concrete.

$$V = \frac{N_d}{B \cdot f_{c28}} \leq 0.3$$

With,

$N_d$ : the normal design force taken from the results given by ETABS.

$B$ : cross section of column.

The following table summarizes the results of the verification of the reduced normal force.

**Table IV-4: Results of the verification of the reduced normal force**

Column section [cm <sup>2</sup> ]	Most stressed	$N_d$ [kN]	$B$ [m <sup>2</sup> ]	$V$	Observation
45 × 45	C23	1025.83	0.2025	0.20	Condition verified
40 × 40	C49	428.96	0.16	0.10	Condition verified

#### ✓ Analysis of the results:

According to the results found, the reduced normal force is verified for the two most stressed column sections.

## IV.7.6 Justification of the results

### IV.7.6.1 Justification of deformations and displacements

The formula for horizontal displacement at each level ( $k$ ) is given in article 4.4.3 of RPA99/2003 by:

$$\delta_k = R \delta_{ek}$$

## Chapter IV. Dynamic study

$\delta_{ek}$  : displacement due to seismic forces  $F_i$  (including the effect of torsion).

R: behavior coefficient ( $R = 3.5$ ).

And that of relative displacement of level (k) with regard to level (k – 1) is :

$$\Delta k = \delta_k - \delta_{k-1}$$

According to article 5.10 of RPA99/2003, the relative lateral displacement of a storey in proportion to the adjacent stories must not exceed 1% of the height of the storey, unless it can be proved that a greater relative displacement can be tolerated.

The results of the verifications are given in the following tables.

**Table IV-5: Verification of relative displacement along x**

Level	$\delta_{ek}$ (cm)	$\delta_k$ (cm)	$\Delta_k$ (cm)	$h_t$ (cm)	$\Delta_k / h_t$ [%]
GL	0	0	0.07	306	0.02
1 <sup>st</sup> F	0.02	0.07	0.28	306	0.09
2 <sup>nd</sup> F	0.1	0.35	0.35	306	0.11
3 <sup>rd</sup> F	0.2	0.7	0.42	306	0.14
4 <sup>th</sup> F	0.32	1.12	0.42	306	0.14
5 <sup>th</sup> F	0.44	1.54	0.35	306	0.11
Terrace F	0.54	1.89	1.89	306	0.62

**Table IV-6: Verification of relative displacement along y**

Level	$\delta_{ek}$ (cm)	$\delta_k$ (cm)	$\Delta_k$ (cm)	$h_t$ (cm)	$\Delta_k / h_t$ [%]
GL	0	0	0.035	306	0.01
1 <sup>st</sup> F	0.01	0.035	0.21	306	0.07
2 <sup>nd</sup> F	0.07	0.245	0.315	306	0.10
3 <sup>rd</sup> F	0.16	0.56	0.315	306	0.10
4 <sup>th</sup> F	0.25	0.875	0.35	306	0.11
5 <sup>th</sup> F	0.35	1.225	0.35	306	0.11
Terrace F	0.45	1.575	1.57	306	0.51

✓ **Analysis of results :**

The results show that the relative displacements between floors are less than 1% of the floor height.

**IV.7.6.2 Justification for overturning**

For the structure to be stable to overturning that may be caused by seismic action, it must verify the following condition in both directions required by article 4.1.1 of RPA99/2003:

$$\frac{M_s}{M_r} = \frac{\sum W_i G_i}{\sum F_i H_i} \geq 1.5$$

With,

$M_s$  : Stabilising moment caused by vertical loads.

$M_r$  : Overturning moment caused by horizontal loads.

$F_i$ : Seismic forces at floor i.

$W_i$ : Weight of floor i.

$G$ : Coordinate of the centre of mass of floor i.

$h_i$ : Height of floor i.

The results for the two directions are given in table's IV-7 and IV-8.

**Table IV-7: The Value of  $M_s$  and  $M_r$  in x direction**

Level	$W_i$ [kN]	$G(x)$ [m]	$W_i.G(x)$ [kN.m]	$F_i$ [kN]	$h_i$ [m]	$F_i.h_i$ [kN.n]
<b>1<sup>st</sup> F</b>	4924.11	13.525	66598.588	181.995	3.06	556.905
<b>2<sup>nd</sup> F</b>	4478.13	13.525	60566.708	331.023	6.12	2025.862
<b>3<sup>rd</sup> F</b>	4478.13	13.525	60566.708	496.538	9.18	4558.189
<b>4<sup>th</sup> F</b>	4478.14	13.525	60566.844	662.049	12.24	8103.465
<b>5<sup>th</sup> F</b>	4478.13	13.555	60701.052	827.558	15.3	12661.636
<b>Terrace F</b>	5205.05	13.557	70564.863	1154.271	18.36	21192.420
<b>Total</b>	379564.763			49098.478		
				<b><math>M_s / M_r = 7.73</math></b>		

Table IV-8: The Value of  $M_s$  and  $M_r$  in y direction

Level	$W_i$ [kN]	$G(x)$ [m]	$W_i \cdot G(x)$ [kN.m]	$F_i$ [kN]	$h_i$ [m]	$F_i \cdot h_i$ [kN.n]
1 <sup>st</sup> F	4924.11	11.230	55297.755	181.995	3.06	556.905
2 <sup>nd</sup> F	4478.13	10.795	48341.413	331.023	6.12	2025.862
3 <sup>rd</sup> F	4478.13	10.795	48341.413	496.535	9.18	4558.189
4 <sup>th</sup> F	4478.14	10.795	48341.521	662.048	12.24	8103.465
5 <sup>th</sup> F	4478.13	10.803	48377.238	827.557	15.3	12661.637
Terrace F	5205.05	10.809	56261.385	1154.27	18.36	21192.412
<b>Total</b>	304960.727			49098.478		
				<b><math>M_s / M_r = 6.21</math></b>		

✓ Analysis of the results :

Overturning stability is checked in both X and Y directions.

#### IV.7.6.3 Justification with regard to the P-delta effect

According to article 5.9 of RPA 99/2003, P-delta effects can be neglected in the case of buildings if the following condition is satisfied at all levels:

$$\theta = \frac{P_k \Delta_k}{V_k h_k} \leq 0.10$$

Such that:

- If  $\theta_k \leq 0.1$ : second-order effects are neglected ;
- If  $0.1 \leq \theta_k \leq 0.2$  : P- delta effects can be taken into account approximately by amplifying the effects of the seismic action calculated using a 1st order elastic analysis by the factor  $1 / (1 - \theta_k)$  ;
- If  $\theta_k \geq 0.2$ : the structure is potentially unstable and must be resized.

With:

$P_k$ : total weight of the structure and associated operating loads above level "k".

$V_k$ : story shear force at level "k".

$\Delta_k$ : relative displacement of level "k" with respect to level "k-1".

$h_k$ : height of story "k".

The results in both directions are given in the following two table.

**Table IV-9: Verification of P-delta effect in x and y directions**

Level	$h_k$ [cm]	$P_k$ [kN]	In the direction of x			In the direction of y		
			$\Delta_k$ [cm]	$V_k$ [kN]	$\theta_k$ [cm]	$\Delta_k$ [cm]	$V_k$ [kN]	$\theta_k$ [cm]
<b>Terrace F</b>	306	28041.69	0.28	1043.46	<b>0.024</b>	0.21	1095	<b>0.0175</b>
<b>5<sup>th</sup> F</b>	306	22836.64	0.35	1771.58	<b>0.014</b>	0.315	1815.72	<b>0.0129</b>
<b>4<sup>th</sup> F</b>	306	18358.51	0.42	2299.46	<b>0.010</b>	0.315	2330.98	<b>0.0081</b>
<b>3<sup>th</sup> F</b>	306	13880.37	0.42	2690.85	<b>0.007</b>	0.35	2721.82	<b>0.0058</b>
<b>2<sup>nd</sup> F</b>	306	09402.24	0.35	2948.83	<b>0.003</b>	0.35	2984.50	<b>0.0036</b>
<b>1<sup>st</sup> F</b>	306	04924.11	1.89	3061.36	<b>0.009</b>	1.57	3105.33	<b>0.008</b>

✓ **Analysis of the results :**

All the values of  $\theta_k$  are less than 0.1, so the P-delta effect has no influence on our structure.

**IV.8 Conclusion**

In this chapter, we have carried out a seismic study of our building, using the ETABS software to simplify the calculations.

From the results obtained, we can conclude that the conditions imposed by the Algerian seismic regulations are all verified, namely:

- ✓ The fundamental period;
- ✓ Mass participation;
- ✓ Shear force at the base;
- ✓ The reduced normal effort of the columns;
- ✓ Relative displacement;
- ✓ Overturning and P-delta effect.

Once this has been done, we can extract the efforts that will allow the calculation of the reinforcement of the structural elements (beams, walls, columns) which will be the subject of the following chapter.

**Chapter V**  
**Reinforcement**  
**of Structural Elements**

### V.1 Introduction :

Structural components that bear weight distribute applied forces and stabilize the structure.

The various calculation combinations are determined first, in our case. We use the following fundamental and accidental combinations to determine the stresses and strains:

✓ **The fundamental combinations:**

$$\text{ULS: } 1.35 G + 1.5 Q$$

$$\text{SLS : } G + Q$$

✓ **Accidental combinations :**

$$0.8 G \pm E_x$$

$$0.8 G \pm E_y$$

$$G + Q + E_x$$

$$G + Q + E_y$$

Once the loads have been calculated, we can determine the reinforcement section required to ensure the strength and stability of our structural elements.

The reinforcement of resistant elements, considering the most unfavorable case, is carried out in accordance with BAEL91 regulations, and verifications in conformity with RPA99/2003 regulations.

### V.2 Study of beams

The beams are estimated for simple bending since they are susceptible to shear forces and bending moments. Furthermore, they are exposed to the weather, thus cracking isn't considered to be highly damaging.



### V.2.1 Calculation of reinforcement

- **Longitudinal reinforcement**

After determining the stresses (M, N, and V) using the ETABS software, the reinforcement is carried out in compliance with the percentage of steel given in article 7.5.2.1 of RPA99/2003 in zone IIb:

- The minimum total percentage of longitudinal reinforcement over the entire length of the beam is 0.5% in any section.
- The maximum total percentage of longitudinal reinforcement is :
  - 4% in the current zone
  - 6% in the overlap zone

- **Example of calculation for principal beam:**

Characteristics of the beam:  $b = 30\text{cm}$ ,  $h = 45\text{cm}$ ,  $d = 0.9 \times h = 0.405\text{m}$

Characteristics of the materials:  $f_{c28} = 25\text{MPa}$ ,  $f_c = 500\text{MPa}$ ,  $f_{bu} = 14.17\text{MPa}$ ,  $f_{t28} = 2.1\text{MPa}$

The reinforcement is calculated using the bending frame made up of rectangular sections (appendix A).

- ✓ **In span :**

$$M_u = 69.764 \text{ kN.m}$$

$$\mu = \frac{M_u}{bd^2 f_{bu}} = 0.10 < \mu_{ab} = 0.187$$

Pivot A ( $\epsilon_s = 10\text{‰}$  ;  $\epsilon_b = 3.5\text{‰}$  ) et  $A_{sc} = 0$

$$\alpha = 1.25(1 - \sqrt{1 - 2\mu}) = 1.25(1 - \sqrt{1 - 2(0.10)}) = 0.13$$

$$\epsilon_b = \frac{\alpha}{1 - \alpha} \epsilon_s = \frac{0.13}{1 - 0.13} 10 = 1.4\text{‰}$$

$$Z = d(1 - 0.4\alpha) = 0.405(1 - 0.4 \times 0.13) = 0.38 \text{ m}$$

$$A_s = \frac{M_u}{Z \cdot \sigma_s} = \frac{69.764}{0.38 \times 434} = 3.45 \text{ cm}^2$$

$$A_s < A_{\min, RPA} = \frac{0.5}{100} \times 30 \times 45 = 6.75 \text{ cm}^2$$

- ✓ **In support :**

$$M_u = 84.977 \text{ kN.m}$$

$$\mu = \frac{M_u}{bd^2f_{bu}} = 0.12 < \mu_{ab} = 0.187$$

Pivot A (  $\epsilon_s = 10\text{‰}$  ;  $\epsilon_b = 3.5\text{‰}$  ) et  $A_{sc} = 0$

$$\alpha = 1.25(1 - \sqrt{1 - 2\mu}) = 1.25(1 - \sqrt{1 - 2(0.12)}) = 0.16$$

$$\epsilon_b = \frac{\alpha}{1-\alpha} \epsilon_s = \frac{0.16}{1-0.16} 10 = 1.9 \text{‰}$$

$$Z = d(1 - 0.4\alpha) = 0.405(1 - 0.4 \times 0.16) = 0.38 \text{ m}$$

$$A_s = \frac{M_u}{Z \cdot \sigma_s} = \frac{84.977}{0.38 \times 434} = 5.15 \text{ cm}^2$$

$$A_s = 5.15 \text{ cm}^2 < A_{\min, \text{RPA}} = \frac{0.5}{100} \times 30 \times 45 = 6.75 \text{ cm}^2$$

✓ **Non-fragility condition :**

In the case of a rectangular section subjected to simple bending, the following condition must be verified:

$$A_{\min} \geq 0.23b \cdot d \frac{f_{t28}}{f_e} = 1.17 \text{ cm}^2$$

$$A = \max \{ A_s ; A_{\min(\text{NBC})} ; A_{\min(\text{RPA})} \}$$

The following tables summarize the reinforcement of the different beams and the choice of bars.

- **Principal beam (30 × 45) cm<sup>2</sup> :**

**Table V-1: Reinforcements sections for principal beams**

Combination	Position	M [kN.m]	A <sub>s</sub> [cm <sup>2</sup> ]	A <sub>min</sub> (NBC) [cm <sup>2</sup> ]	A <sub>min</sub> (RPA) [cm <sup>2</sup> ]	Choice of bars	A <sub>adopted</sub> [cm <sup>2</sup> ]
ULS	Span	- 69.764	3.94	1.17	6.75	3HA14+3HA12	8.01
	Support	-84.977	4.9			3HA14+3HA12	8.01

- Secondary beam (30 × 40) cm<sup>2</sup> linked to shear walls :

**Table V-2 : Reinforcements sections for secondary beams linked to shear walls**

Combinaison	Position	M [kN.m]	A <sub>s</sub> [cm <sup>2</sup> ]	A <sub>min</sub> (NBC) [cm <sup>2</sup> ]	A <sub>min</sub> (RPA) [cm <sup>2</sup> ]	Choice of bars	A <sub>adopted</sub> [cm <sup>2</sup> ]
ULS	Support	-51.373	3.3	1.04	6	2× 3HA14	9.24
	Span	28.07	1.77				
G + Q + E	Support	-112.094	7.71			3HA14+3HA12	8.01

- Secondary beam (30 × 40) cm<sup>2</sup>:

**Table V-3: Reinforcements sections for secondary beams**

Combinaison	Position	M [kN.m]	A <sub>s</sub> [cm <sup>2</sup> ]	A <sub>min</sub> (NBC) [cm <sup>2</sup> ]	A <sub>min</sub> (RPA) [cm <sup>2</sup> ]	Choice of bars	A <sub>adopted</sub> [cm <sup>2</sup> ]
ULS	Support	-21.381	1.34	1.04	6	2× 3HA14	9.24
	Span	2.041	0.13				

- Tie Beam (30 × 25) cm<sup>2</sup> :

**Table V-4: Reinforcements sections for tie beams**

Combinaison	Position	M [kN.m]	A <sub>s</sub> [cm <sup>2</sup> ]	A <sub>min</sub> (NBC) [cm <sup>2</sup> ]	A <sub>min</sub> (RPA) [cm <sup>2</sup> ]	Choice of bars	A <sub>adopted</sub> [cm <sup>2</sup> ]
ULS	Support	-5.581	0.71	0.54	3.15	3HA12	3.39
	Span	-0.824	0.1				
G + Q + E	Support	-7.931	1.02				

✓ **Analysis of results:**

The calculated reinforcement is less than that required by RPA99/2003. This is why the choice of reinforcement was made in relation to A<sub>s min, RPA</sub>.

### V.2.2 Service limit state verification

- Stress evaluation :

G : center of gravity.

$A_{sc}$ : Compression reinforcement section.

$A_s$ : Tensile reinforcement section.

$$\sum S_{/G} = 0$$

$$\frac{b}{2}y^2 + n A_{sc} (y-d') - n A_s (d-y) = 0$$

y : distance between the neutral axis and the furthest fibre.

$$\sigma_b = \frac{M_s}{I} y \leq \bar{\sigma}_b = 0.6 f_{c28}$$

$$\sigma_s = n \frac{M_s}{I} (d-y) \leq \bar{\sigma}_s = f_e / Y_s$$

With,  $I = \frac{b}{3}y^3 + n A_{sc} (y-d')^2 + n A_s (d-y)^2$

The verification of the stresses for the different beams is summarized in the following table.

**Table V-5: Verification of the stresses**

Beam section [cm <sup>2</sup> ]	$M_s$ [kN.m]	y [m]	I [m <sup>4</sup> ]	Concrete		Steel		Observation
				$\sigma_b$ [MP]	$\bar{\sigma}_b$ [MP]	$\sigma_s$ [MPa]	$\bar{\sigma}_s$ [MP]	
<b>30×45</b>	-62.01	0.144	$8.1 \times 10^{-4}$	11.2	18	302.8	434	Checked
<b>30×40</b>	-37.347	0.108	$7.6 \times 10^{-4}$	8.77	18	185.0	434	Checked
<b>30×25</b>	-2.85	0.08	$1.9 \times 10^{-4}$	1.2	18	25	434	Checked

✓ **Verification of the shear stress :**

In accordance with article A.5.1,21 of BAEL91, the maximum tangent stress of a beam in the case of straight transversal reinforcement must verify the following condition:

$$\tau_u = \frac{V_u}{b.d} \leq \min (0.2f_{cj} / \gamma_b, 5\text{MPa}) = 3.33 \text{ MPa}$$

With,

$V_u$ : maximum shear force

$b$  : beam width

$d$  : useful height

The results of the verification are summarized in the following table

**Table V-6: Shear stress verification for beams**

Beam section [cm <sup>2</sup> ]	$V_u$ [kN]	$\tau_u$ [MPa]	$\bar{\tau}_u$ [MPa]	Observation
<b>30×45</b>	-118.46	0.97	3.33	Checked
<b>30×40</b>	76.51	0.70	3.3	Checked
<b>30×25</b>	-6.15	0.1	3.33	Checked

• **Transversal reinforcement :**

According to article A.5.1,23 of BAEL91 :

$$\frac{A_t}{b.S_t} \geq \frac{\tau_u - 0.3K.f_{tj}}{0.8 f_e}$$

With,

$k = 1$  general case;

$f_{tj} = \min (f_{tj} ; 3.3\text{MPa}) = 2.1\text{MPa}$

To calculate the spacing  $S_t$ , we adopt a diameter equal to 8mm :

4HA8 (frames + bracket)      →       $A_t = 2.01 \text{ cm}^2$

We have:

$$S_t \leq \frac{A_t \cdot 0.8 \cdot f_e}{b (\tau_u - 0.3K f_{tj})}$$

According to article 7.5.2.2 of RPA99/2003, the maximum spacing between transversal reinforcements is determined as follows:

$$S_t \leq \min (h/4; 12\phi_l) \quad \text{Nodal zone}$$

$$S_t \leq h/2 \quad \text{Common zone}$$

Where  $\phi_l$  is the value of the smallest diameter of the longitudinal reinforcement.

The minimum quantity of reinforcement is:

$$A_t = 0.003 \times s_t \times b$$

The calculations are given in the following table.

**Table V-7: Transversal reinforcements sections**

Beam section [cm <sup>2</sup> ]	V <sub>u</sub> [kN]	τ <sub>u</sub> [MPa]	BAEL91	RPA99		S <sub>t</sub> [cm]		A <sub>t</sub> [cm <sup>2</sup> ]
			S <sub>t</sub> [cm]	S <sub>t</sub> [cm] NZ	S <sub>t</sub> [cm] CZ	S <sub>t</sub> [cm] NZ	S <sub>t</sub> [cm] CZ	
<b>30×45</b>	-118.46	0.97	77	11.25	22.5	10	20	1.8
<b>30×40</b>	76.51	0.70	33.5	10	20	10	20	1.8

➔ We use a frame plus a bracket HA8 for both beams.

✓ **Additional conditions :**

$$\phi_t = 8\text{mm} \leq \min \left( \frac{h}{35}; \phi_l; \frac{b}{10} \right) = 12.8 \text{ mm}$$

In nodal zone:

$$\frac{A_t f_e}{b \cdot S_t} = 3 \text{ MPa} \geq 0.4 \text{ Mpa}$$

$$S_t = 10 \text{ cm} \leq \min (0.9d ; 40\text{cm}) = 36.45 \text{ cm}$$

In common zone:

$$\frac{A_t f_e}{b \cdot S_t} = 3 \text{ MPa} \geq 0.4 \text{ Mpa}$$

$$S_t = 20 \text{ cm} \leq \min ( 0.9d ; 40\text{cm} ) = 36.45 \text{ cm}$$

All the conditions of RPA99/2003 and BAEL91 are met.

**- Length of overlap :**

According to article 7.5.2.1 of RPA99/2003, the overlap length is :

$$L_r = 50 \phi \quad \text{in zone IIb}$$

We have :  $\phi = 14\text{mm}$       so:  $L_r = 70 \text{ cm}$

Length of nodal zone:

$$l' = 2 \times h$$

$$l' = 90 \text{ cm} \quad \rightarrow \text{ Main beams}$$

$$l' = 80 \text{ cm} \quad \rightarrow \text{ Secondary beams}$$

**V.2.3 Reinforcement details**

The reinforcement diagrams are shown in the following figures.

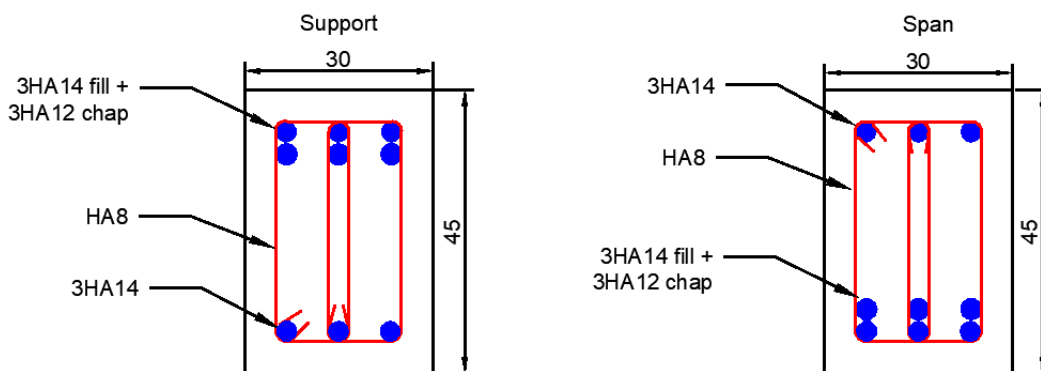

**Figure V-1: Reinforcement details for principal beam**

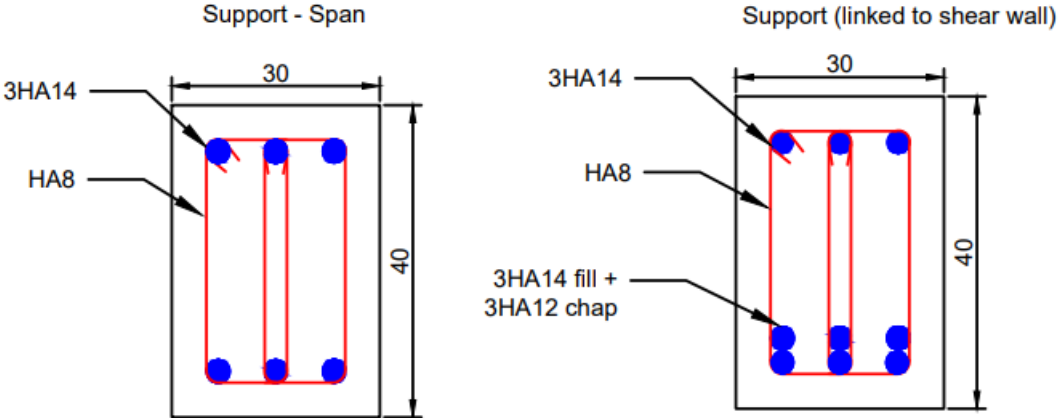

Figure V-2: Reinforcement details for secondary beam

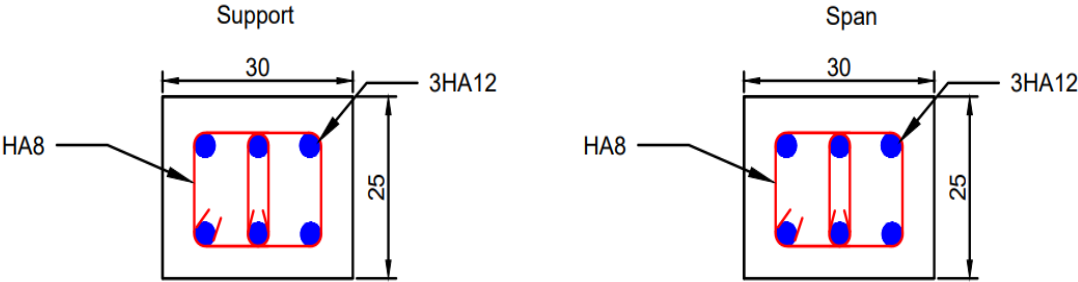

Figure V-3: Reinforcement details for tie beam

V.3 Study of columns

Columns are subject to normal forces, bending moments and shear forces. They must therefore be designed and reinforced in compound bending according to the most unfavorable combination, taking into account the following three load cases:

- $N_{max} \rightarrow M_{correspondent}$
- $N_{min} \rightarrow M_{correspondent}$
- $M_{max} \rightarrow N_{correspondent}$



### V.3.1 Calculation of reinforcement

- **Longitudinal reinforcement :**

According to article 7.4.2.1, their minimum percentage in our case is :

0.9% in zones IIb and III

The maximum percentage is:

3% in current zones

6% in the overlap zone

The minimum diameter is 12 mm.

Using the SOCOTEC software, the longitudinal reinforcement obtained for the two sections of column are summarized in the following tables.

**Table V-8: Reinforcement Section for Columns (45×45) cm<sup>2</sup>**

Level		Combination	N [kN]	M [kN.m ]	A <sub>s</sub> [cm <sup>2</sup> ]	A <sub>min</sub> (RPA) [cm <sup>2</sup> ]	Choive of bars	A <sub>adopted</sub> [cm <sup>2</sup> ]
<b>Ground level ; 1<sup>st</sup> ; 2<sup>nd</sup></b>	N <sub>min</sub>	ULS	-1152.09	-0.12	13.26	18.22	<b>4HA16 + 4HA20</b>	20.61
	N <sub>max</sub>	0.8G+E	500.27	1.83	0			
	M <sub>max</sub>	G+Q+E	-62.2	55.78	3.82			
<b>3<sup>rd</sup> ; 4<sup>th</sup> ; 5<sup>th</sup></b>	N <sub>min</sub>	ULS	-566.06	10.36	7.11			
	N <sub>max</sub>	0.8G+E	135.9	2.314	0			
	M <sub>max</sub>	G+Q+E	-39.94	61.11	3.87			

Table V-9: Reinforcement Section for Columns (40×40) cm<sup>2</sup>

Level		Combination	N [kN]	M [kN.m]	A <sub>s</sub> [cm <sup>2</sup> ]	A <sub>min</sub> (RPA) [cm <sup>2</sup> ]	Choice of bars	A <sub>adopted</sub> [cm <sup>2</sup> ]
<b>Ground level ; 1<sup>st</sup> ; 2<sup>nd</sup></b>	N <sub>min</sub>	G+Q+E	-429.41	-7.313	5.42	14.4	<b>8HA16</b>	16.08
	N <sub>max</sub>	0.8G+E	135.9	2.314	0			
	M <sub>max</sub>	G+Q+E	51.51	23.68	0.86			
<b>3<sup>rd</sup> ; 4<sup>th</sup> ; 5<sup>th</sup></b>	N <sub>min</sub>	G+Q+E	-207.21	-22.79	3.88			
	N <sub>max</sub>	0.8G+E	61.3	14.99	0.19			
	M <sub>max</sub>	G+Q+E	28.28	22.87	1.09			

✓ **Non-fragility condition:**

In the case of a section subjected to compound bending, the following condition must be verified:

$$A_{\min} \geq 0.23b.d \frac{f_{t28}}{f_e}$$

Column (45×45) cm<sup>2</sup>:  $A_{\min} \geq 1.76 \text{ cm}^2$

Column (40 ×40) cm<sup>2</sup>:  $A_{\min} \geq 1.39 \text{ cm}^2$

Therefore, the conditions are verified.

- **Transversal reinforcement :**

According to article 7.4.2.2 of RPA99/2003, transversal reinforcement is calculated using the following formula:

$$\frac{A_t}{t} = \frac{\rho_a V_u}{h_1 \cdot f_e}$$

With,

V<sub>u</sub> : design shear force ;

h<sub>1</sub> : total height of the section;

f<sub>e</sub> : yield stress of the transverse reinforcing steel;

## Chapter V. Reinforcement of structural elements

---

$\rho$  : correction coefficient which takes account of the brittle mode of failure by shear force, it is taken to be equal to 2.50 if the geometric slenderness  $\lambda_g$  in the direction considered is greater than or equal to 5 and to 3.75 otherwise.

Where,  $\lambda_g = \frac{L_f}{b}$

$$L_f = 0.7 \times h = 2.142 \text{ m}$$

t: spacing of the transversal reinforcements. In addition, the maximum value of this spacing is fixed as follows:

In nodal zone :

$$t \leq 10 \text{ cm} \quad \text{in zones IIb}$$

→ We adopt  $t = 10 \text{ cm}$

In current zone:

$$t' \leq \text{Min} (b_1/2, h_1/2, 10 \phi_l) \quad \text{in zones IIb}$$

Where  $\phi_l$  is the minimum diameter of the longitudinal reinforcement of the column.

→ We adopt  $t = 16 \text{ cm}$

The reinforcements sections in the nodal and current zones are given in the following table.

**Table V-10: Transversal reinforcements sections for columns**

Column section [cm <sup>2</sup> ]	$\lambda_g$	$\rho_g$	$V_u$ (KN)	$A_t$ (nodal zone)	$A_t$ (current zone)
<b>45×45</b>	4.76	3.75	35.80	0.60	0.95
<b>40×40</b>	5.35	2.50	14.75	0.20	0.3

The minimum quantity of transversal reinforcement  $A_t / t.b_1$  in % is given as follows:

$$\text{If } \lambda_g \geq 5 : 0.3 \%$$

$$\text{If } \lambda_g \geq 3 : 0.8 \%$$

If  $3 < \lambda_g < 5$  : interpolate between the above limit values

The table below summarize the results of the calculations based on RPA99/2003.

**Table V-11: Transversal reinforcement section according to RPA99/2003**

Column section [cm <sup>2</sup> ]	A <sub>t</sub> (nodal zone)	A <sub>t</sub> (current zone)
45×45	1.35	2.16
40×40	1.2	1.92

Thus, the transversal reinforcement adopted by the RPA99/2003 is given, because:

$$A_{t,RPA} > A_{t,calculated}$$

We therefore use 2HA10 frames.

✓ **Verification of the shear stress :**

The shear stress under seismic conditions must be less than or equal to the following limit value:

$$\tau_{bu} = \rho_d f_{c28}$$

With,

$$\left\{ \begin{array}{l} \rho_d = 0.075 \quad \text{if } \lambda_g \geq 5 \\ \rho_d = 0.04 \quad \text{if } \lambda_g < 5 \end{array} \right.$$

The following table summarizes the results.

**Table V-12: Shear stress verification for columns**

Column section [cm <sup>2</sup> ]	$\lambda_g$	$\rho_d$	V <sub>u</sub> (kN)	$\tau$ [MPa]	$\tau_{bu}$ [MPa]	Observation
45×45	4.76	0.040	35.80	0.19	1	Checked
40×40	5.35	0.075	14.75	0.10	1	Checked

- **Length of overlap :**

According to article 7.4.2 of RPA99/2003, the minimum overlap length is 50  $\phi$  in zone IIb, so :

$$L_r = 80 \text{ cm} \quad \text{for a } 45 \times 45 \text{ column}$$

$$L_r = 90 \text{ cm} \quad \text{for a } 40 \times 40 \text{ column}$$

### V.3.2 Reinforcement details

The reinforcement diagram for both columns are shown in the following figure.

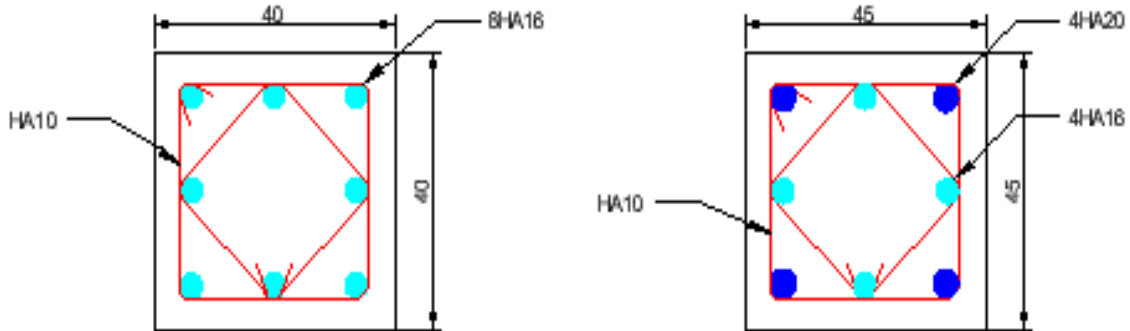

Figure V-4: Reinforcement details for columns

### V.4 Study of shear walls

A shear wall, also known as a bearing wall, is an active structural component of a building that sustains the weight of objects resting upon it by transmitting that weight to a foundation structure. It also bears the majority of the horizontal forces generated by earthquakes.

Subject to a normal force  $N$ , a shear force  $V$ , and a bending moment  $M$ , which is highest in the embedding section, a shear wall is regarded as a bracket implanted at its base.

Reinforced concrete walls must be justified as follows:

- Form stability justification
- Shear strength
- Resistance to combined bending

Taking into account the requirements of RPA99/2003 and DTR.B.V.2.42, the shear walls are calculated in compound bending with a shear force, which will be drawn from the ETABS software under the following seismic conditions:

✓ **The fundamental combinations:**

ULS:  $1.35 G + 1.5 Q$

SLS :  $G + Q$

✓ **Accidental combinations :**

$0.8 G \pm E_x$

$0.8 G \pm E_y$

$G + Q + E_x$

$G + Q + E_y$

**V.4.1 Shear wall arrangement and characteristics**

The following figure show the arrangement of the shear walls in our structure.

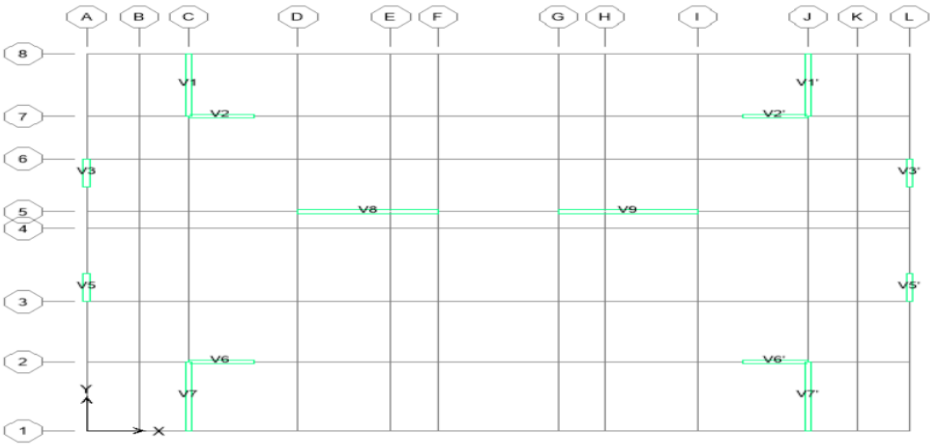

**Figure V-5: Dimension of the shear walls**

The following table regroup the shear walls of our structure and their geometrics characteristics.

**Table V-13: Dimension of the shear walls**

Wall	Length - L (m)	Thickness – e (m)
V1, V1'	3.55	0.2
V2, V2'	2.15	0.2
V3, V3', V5, V5'	1.60	0.2
V6, V6'	2.15	0.2
V7, V7'	3.45	0.2
V8, V9	4.15	0.2

### V.4.2 Reinforcement calculations

The shear walls will be calculated by means of the Navier method, which is a simplified method based on tension.

The stresses are calculated using the material resistance formula as follows:

$$\sigma_{\text{tension}} = \frac{N}{A} - \frac{M.V}{I}$$

$$\sigma_{\text{compression}} = \frac{N}{A} + \frac{M.V}{I}$$

With,

N: applied normal force

M: applied bending moment

S: cross-section of wall

V: distance between the centre of gravity of the wall and the furthest fibre

I: moment of inertia

- **Tensioned length and compressed length :**

$$L_t = L \times \frac{\sigma_t}{\sigma_t + \sigma_c}$$

$$L_c = L - L_t$$

L: the length of the wall

There are three cases:

1<sup>st</sup> case:

$(\sigma_{\text{tension}} \text{ et } \sigma_{\text{compression}}) > 0$  : the section of the wall is fully compressed.

The minimum  $A_c$  required by RPA99/2003 (fig.7.1) reinforces the current zone.

2<sup>nd</sup> case:

$(\sigma_{\text{tension}} \text{ et } \sigma_{\text{compression}}) < 0$  : the wall section is fully tensioned

The tensile stress volume is calculated by:  $N_t = \frac{\sigma_t + \sigma_c}{2} \times L_t \times e$

3<sup>rd</sup> case:

( $\sigma_{\text{tension}}$  et  $\sigma_{\text{compression}}$ ) of different sign : the cross-section of the wall is partially compressed

The tensile stress volume is calculated by:  $N_t = \frac{\sigma_t}{2} \times L_t \times e$

- **Example of calculation for wall 9:**

Using the ETABS software, the most unfavourable stresses are summarised in the following table.

**Table V-14: Design stresses for wall 9**

Wall	Combination	Normal effort $N_{Rx}$ [kN]	Shear force $V_{Ry}$ [kN]	Bending moment $M_{Rz}$ [kN.m]
V9	G + Q + Ex	1396.15	751.67	- 3138.461

✓ Characteristics of the wall :

$$e = 0.20 \text{ m}$$

$$L = 4.15 \text{ m}$$

$$A = e \times L = 4.15 \times 0.20 = 0.83 \text{ m}^2$$

$$I = \frac{e \times L^3}{12} = \frac{0.20 \times 4.15^3}{12} = 1.62 \text{ m}^4$$

$$\sigma_t = \frac{139.615}{0.83} - \frac{313.86 \times 2.30}{1.62} = 596.71 \text{ t/m}^2$$

$$\sigma_c = \frac{139.615}{0.83} + \frac{313.86 \times 2.30}{1.62} = - 293.20 \text{ t/m}^2$$

$\sigma_t$  et  $\sigma_c$  are of different signs: The section is partially compressed

- **Tensioned length:**

$$L_t = 4.15 \times \frac{596.71}{596.71 + 293.20} = 3.08 \text{ m}$$



- **Compressed length:**

$$L_c = 4.15 - 3.08 = 1.07 \text{ m}$$

**a) Calculation of vertical reinforcement**

- Tensile stress :

$$N_t = \frac{596.71}{2} \times 3.08 \times 0.20 = 184.05 \text{ t}$$

- Reinforcement cross-section :

$$A_s = \frac{184.05 \times 10^3}{500 \times 10} = 36.81 \text{ cm}^2$$

According to article 7.7.4.1 of RPA99/2003, when a part of the wall is tensioned under the action of vertical and horizontal forces, the tensile stress must be taken entirely by the reinforcement, the minimum percentage of vertical reinforcement over the whole tensioned zone is 0.20%, i.e. :

$$A_s > A_{\min, RPA} = 0.2\% \times L_t \times e = 12.34 \text{ cm}^2$$

- **Arrangement of reinforcement :**

As shown in the figure bellow, the spacing of the vertical bars at the end of the wall must be reduced by half over 1/10 of the width of the wall, this spacing must not exceed 15cm.

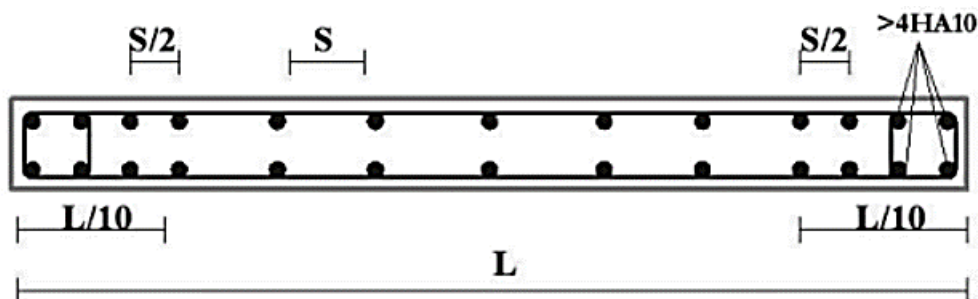

**Figure V-6 : Arrangement of Vertical Reinforcement in Walls**

We take a spacing of 15cm in the common area and 10cm at the extremities.

### b) Shear stress verification

According to article 7.7.2 of RPA99/2003, the shear stress in concrete is limited as follows:

$$\tau_b \leq \bar{\tau}_b = 0.2 f_{c28} = 5 \text{ MPa}$$

Where,

$$\tau_b = \frac{\bar{V}}{e \times d}$$

With,

$$\bar{V} = 1.4 V_{u \text{ calcul}}$$

e : thickness of the wall ;

d : useful height = 0.9h ;

h : total height of the section.

$$\tau_b = \frac{1.4 \times 751.67}{0.20 \times 0.9 \times 4.60} = 1.3 \text{ MPa} \leq \bar{\tau}_b = 5 \text{ MPa}$$

The shear stress is therefore checked.

### c) Horizontal reinforcement

According to article 7.7.4.2 of RPA99/2003, the minimum percentage of horizontal reinforcement for 1 linear meter:

$$A_h \geq 0.15\% \times e \times l = \frac{0.15}{100} \times 20 \times 100 = 3 \text{ cm}^2/\text{ml}$$

We adopt **4HA10** = 3.14 cm<sup>2</sup>

#### ✓ Spacing :

Article 7.7.4.3 of RPA99/2003 requires that the spacing of the horizontal and vertical bars should be as follows:

$$S_t \leq \min (1.5e; 30\text{cm}) = 30\text{cm}$$

✓ **Diameters:**

Article 7.7.4.3 of RPA99/2003 requires that the diameter of the vertical and horizontal bars of the sails (with the exception of the end zones) should not exceed 1/10 of the thickness of the sail, i.e.:

$$\Phi_v \leq \frac{20}{10} = 2\text{cm}$$

✓ **Number of pins :**

According to article 7.7.4.3 of RPA99/2003, the two layers of reinforcement must be connected with at least 4 pins per square meter, in each layer, the horizontal reinforcement must be arranged towards the outside.

$$N = 4 \times 0.20 \times 4.60 = 3.68 \text{ i.e. 4 pins per layer.}$$

The following tables show the results of the stresses of shear walls.

**Table V-15: Results of stresses of shear walls**

Wall	Level	Length [m]	$N_{Rx}$ [kN]	$M_{Rz}$ [kN.m]	$\sigma_t$ [t/m <sup>2</sup> ]	$\sigma_c$ [t/m <sup>2</sup> ]	$L_t$ [m]
<b>V9, V8</b>	GL ,1 <sup>st</sup> , 2 <sup>nd</sup>	4.15	-1396.15	-3138.46	596.72	-293.21	3.08
	3 <sup>rd</sup> , 5 <sup>th</sup> , 6 <sup>th</sup>		-798.97	1357.07	-279.25	105.56	3.33
<b>V1', V1</b>	GL ,1 <sup>st</sup> , 2 <sup>nd</sup>	3.55	-1135.24	-1795.73	587.36	-267.58	2.44
	3 <sup>rd</sup> , 5 <sup>th</sup> , 6 <sup>th</sup>		-590.75	-798.47	273.28	-106.87	2.55
<b>V7', V7</b>	GL ,1 <sup>st</sup> , 2 <sup>nd</sup>	3.45	-1223.24	-440.53	406.70	-173.10	2.90
	3 <sup>rd</sup> , 5 <sup>th</sup> , 6 <sup>th</sup>		-654.70	-1002.89	281.57	-113.70	2.78
<b>V2', V2</b>	GL ,1 <sup>st</sup> , 2 <sup>nd</sup>	2.15	294.12	58.66	-106.47	-30.32	1.67
	3 <sup>rd</sup> , 5 <sup>th</sup> , 6 <sup>th</sup>		-312.94	-299.33	266.83	-121.27	1.48
<b>V6, V6'</b>	GL ,1 <sup>st</sup> , 2 <sup>nd</sup>	2.15	-733.25	-615.56	570.02	-228.97	1.53
	3 <sup>rd</sup> , 5 <sup>th</sup> , 6 <sup>th</sup>		-488.14	-71.12	298.77	-150.08	1.43
<b>V3', V3</b>	GL ,1 <sup>st</sup> , 2 <sup>nd</sup>	1.60	-270.75	-98.16	199.57	-30.35	1.39
	3 <sup>rd</sup> , 5 <sup>th</sup> , 6 <sup>th</sup>		-312.94	-299.33	266.83	-121.27	1.48
<b>V5', V5'</b>	GL ,1 <sup>st</sup> , 2 <sup>nd</sup>	1.60	-536.58	77.59	-258.61	-76.76	1.23
	3 <sup>rd</sup> , 5 <sup>th</sup> , 6 <sup>th</sup>		-261.77	-100.96	200.12	-36.51	1.35

## Chapter V. Reinforcement of structural elements

The following table shows the reinforcement sections and reinforcement adopted for shear walls.

**Table V-16: Results of reinforcement of shear walls on all levels**

Wall	Section [cm <sup>2</sup> ]	Level	L <sub>t</sub> [m]	A <sub>t</sub> [cm <sup>2</sup> ]	A <sub>min,RPA</sub> [cm <sup>2</sup> ]	Reinforcement adopted
V9, V8	415 × 20	GL, 1 <sup>st</sup> , 2 <sup>nd</sup>	3.08	<b>36.81</b>	10.85	2×2×5HA14 s = 10 2×21HA14 s = 15
		3 <sup>rd</sup> , 5 <sup>th</sup> , 6 <sup>th</sup>	3.33	<b>18.64</b>	13.35	2×2×5HA14 s = 10 2×21HA14 s = 15
V1', V1	355 × 20	GL, 1 <sup>st</sup> , 2 <sup>nd</sup>	2.44	<b>28.65</b>	9.76	2×2×3HA14 s = 10 2×19HA14 s = 15
		3 <sup>rd</sup> , 5 <sup>th</sup> , 6 <sup>th</sup>	2.55	<b>13.94</b>	10.20	2×2×3HA14 s = 10 2×19HA14 s = 15
V7', V7	390 × 20	GL, 1 <sup>st</sup> , 2 <sup>nd</sup>	2.90	<b>28.01</b>	11.51	2×2×3HA14 s = 10 2×22HA14 s = 15
		3 <sup>rd</sup> , 5 <sup>th</sup> , 6 <sup>th</sup>	2.78	<b>15.64</b>	11.11	2×2×3HA14 s = 10 2×22HA14 s = 15
V2', V2	215 × 20	GL, 1 <sup>st</sup> , 2 <sup>nd</sup>	1.67	<b>17.79</b>	6.17	2×2×2HA14 s = 10 2×11HA14 s = 15
		3 <sup>rd</sup> , 5 <sup>th</sup> , 6 <sup>th</sup>	1.48	<b>7.89</b>	5.91	2×2×2HA14 s = 10 2×11HA14 s = 15
V6', V6	215 × 20	GL, 1 <sup>st</sup> , 2 <sup>nd</sup>	1.53	<b>17.49</b>	6.14	2×2×2HA14 s = 10 2×11HA14 s = 15
		3 <sup>rd</sup> , 5 <sup>th</sup> , 6 <sup>th</sup>	1.43	<b>8.55</b>	5.72	2×2×2HA14 s = 10 2×11HA14 s = 15
V3', V3	160 × 20	GL, 1 <sup>st</sup> , 2 <sup>nd</sup>	1.39	<b>13.15</b>	4.18	2×2×2HA14 s = 10 2×8HA14 s = 15
		3 <sup>rd</sup> , 5 <sup>th</sup> , 6 <sup>th</sup>	1.48	5.54	<b>5.56</b>	2×2×2HA14 s = 10 2×8HA14 s = 15
V5', V5	160 × 20	GL, 1 <sup>st</sup> , 2 <sup>nd</sup>	1.23	<b>6.38</b>	4.94	2×2×2HA14 s = 10 2×8HA14 s = 15
		3 <sup>rd</sup> , 5 <sup>th</sup> , 6 <sup>th</sup>	1.35	<b>5.42</b>	5.41	2×2×2HA14 s = 10 2×8HA14 s = 15

The verification of the shear stresses is summarized in the following table.

**Table V-17: Results of shear stress verification**

Wall	L [m]	e [m]	$V_{Ry}$ [kN]	$\tau_b$ [MPa]	$\bar{\tau}_b$ [MPa]	Observation
<b>V9, V8</b>	4.15	0.2	751.67	1.27	5	Checked
<b>V1', V1</b>	3.55	0.2	544.16	1.19	5	Checked
<b>V7', V7</b>	3.9	0.2	177.94	0.35	5	Checked
<b>V2', V2, V6', V6</b>	2.15	0.2	433.96	1.57	5	Checked
<b>V3', V3, V5', V5</b>	1.6	0.2	176.23	0.86	5	Checked

### V.4.3 Reinforcement details

The following figure shows the reinforcement diagram for shear wall.

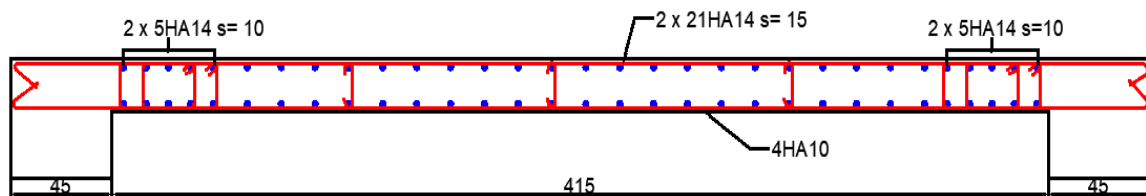

**Figure V-7: Reinforcement details for shear wall V9**

### V.5 Conclusion

In this chapter, we have carried out the calculation of the reinforcement of the structural elements (column, beam and shear wall) according to the Algerian standards and regulations. The feasibility of the reinforcement and the verification of the stresses validated the choice of the sections of these elements.

## **Chapter VI**

# **Study of the Infrastructure**

### VI.1 Introduction

The foundations are an essential part of the project's infrastructure. They ensure the stability of the structure and the proper transmission of loads and overloads from the superstructure (floor, columns and walls...) to the ground.

This requires, on the one hand, an effective connection between the foundations and the superstructure, either directly (as in the case of footings resting on the ground → superficial foundations) or indirectly through other organs (footings on piles → deep foundation) and, on the other hand, a good anchoring at ground level.

The various functions of a foundation:

- ✓ Ensures that the structure is embedded in the ground.
- ✓ Ensures the stability of the structure.
- ✓ Transfers forces from the superstructure to the ground.
- ✓ Limits differential settlement to acceptable levels.

### VI.2 Choice of foundations type

The choice of foundation type depends on several factors:

- ✓ The nature and quality of the foundation and the weight of the superstructure.
- ✓ The quality and quantity of the loads applied to the structure.
- ✓ The type of structure to be built (house, skyscraper, bridge...).
- ✓ The nature and homogeneity of the ground.
- ✓ The bearing capacity of the foundation.
- ✓ Economic reasons.
- ✓ The location (urban; mountain; seaside...).
- ✓ The type of foundation (dry soil, presence of water...).

According to the geotechnical report, the permissible stress of the soil in which the building is to be constructed is 2.2 bars for an anchoring depth of 3 meters.

As stated in article 10.1.4.1 of RPA99/2003, superficial foundations are dimensioned according to the following combinations of actions:

- ✓  $G + Q + E$
- ✓  $0.8G \pm E$

As well as the combinations referenced by the BAEL91:

- ✓  $1.35G + 1.5Q$
- ✓  $G + Q$

The choice of foundations to adopt for our structure involves first the verification of the isolated footings and then the continuous footings.

- Isolated footing:

Generally, foundations have to comply with the following ratio:

$$\frac{N}{S} \leq \overline{\sigma_{\text{soil}}}$$

With,

$N$  : Normal force acting on the footing, obtained using the ETABS software.

$S$  : Supporting surface of footing.

$\overline{\sigma_{\text{soil}}}$  : Permissible soil stress.

For this verification, we take the footing with the highest stress  $N$  as shown in the following figure:

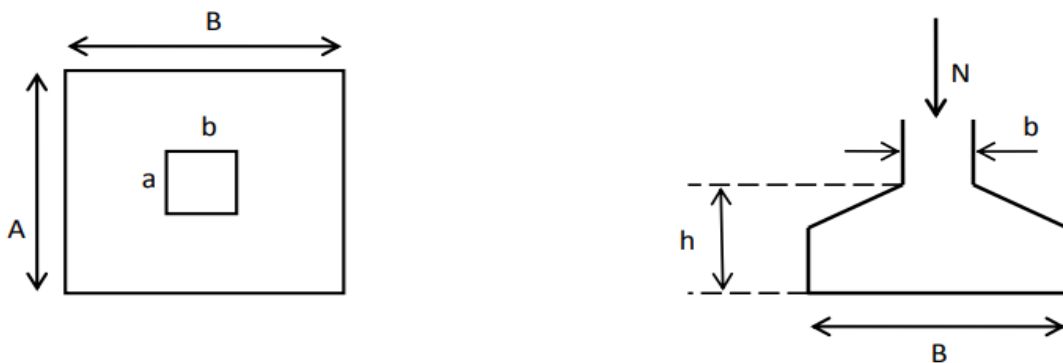

**Figure VI-1: Diagram of an isolated footing**



We have:  $N = 1343.68 \text{ kN}$  ;  $\bar{\sigma}_s = 220 \text{ kN/m}^2$

$$\frac{N}{S} \leq \bar{\sigma}_{\text{soil}} \rightarrow S \geq \frac{N}{\bar{\sigma}_{\text{soil}}} = \frac{1343.68}{220} = 6.10 \text{ m}^2$$

We adopt  $S = 7 \text{ m}^2$  (  $A = B = 3.5 \text{ m}$  )

The results show that there will be an overlap between the footings, given that there is a distance between the axes of the columns in the  $xx'$  direction of 1.62 m, so the choice of isolated footings in our case is not appropriate.

We will opt for **crossed strip footings** for our foundation.

### VI.3 Study of strip footing

The method for calculating a strip footing is the same as for an insulated footing, the main reinforcement is transverse steel, and the secondary reinforcement is used for distribution reinforcement.

#### ✓ Characteristics:

$f_{c28} = 25 \text{ MPa}$  ;  $f_c = 500 \text{ MPa}$  ;  $\gamma_{\text{soil}} = 18 \text{ kN/m}^3$  ;  $\gamma_{\text{concrete}} = 25 \text{ kN/m}^3$  ;  $\sigma_s = 434 \text{ MPa}$

#### VI.3.1 Dimensioning of the crossed strip footings

##### VI.3.1.1 Footing width determination

The width of the footing is calculated so that the calculated stress is less than the permissible stress of the soil. To do this, the infrastructure is modelled using ETABS and the loads that will be taken by each footing are obtained, taking into account its own weight, the weight of the column anchors, the weight of the wall anchors and the weight of the soil.

The width of the footing must therefore satisfy the following condition:

$$\frac{N}{B \times L} \leq \bar{\sigma}_s$$

$$N = \sum N_i$$

$N_i$  : normal force emitted by the column, soil and footing

Weight of soil:  $N_1 = (h_{\text{anchorage}} - H) \times L \times B \times \gamma_{\text{soil}}$

Dead weight of footing:  $N_2 = L \times B \times H \times \gamma_{\text{concrete}}$

L: length of the footing

$$\bar{\sigma}_s = 220 \text{ kN/m}^2$$

### VI.3.1.2 Footing height determination

The height of the continuous footing is defined by:

$$h = d + 5 \text{ cm} \quad \text{with: } d \geq \frac{B - b}{4}$$

d: useful height (m)

b: sides of the column (m)

$$\rightarrow h \geq \frac{B - b}{4} + 5 \text{ cm}$$

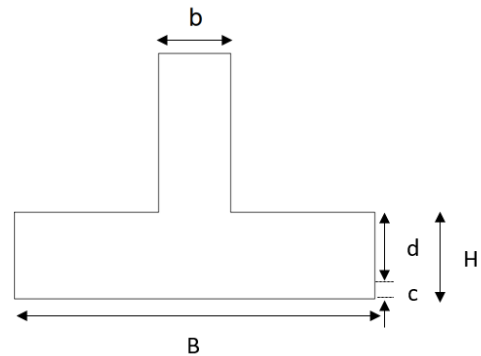

Figure VI-2: Dimension of the footing

The following tables summarizes the service limit state verification results for each footing in both the transversal and longitudinal directions. For each footing a width B is imposed and the stress is compared with the permissible stress of the soil  $\bar{\sigma}_s = 220 \text{ kN/m}^2$ .

Table VI-1: The SLS verification in transversal direction

	L [m]	B adopted [m]	h [m]	weight of the soil [kN]	Dead weight of footing [kN]	Vertical load [kN]	Total load [kN]	service stress [kN/m <sup>2</sup> ]
SF 1	7.1	1.1	0.35	372.54	68.337	886.605	1327.48	169.97
SF 1'	7.1	1.1	0.35	372.54	68.337	886.050	1326.92	169.90
SF 2	9.25	1.1	0.35	485.35	89.031	1249.610	1823.99	179.26
SF 2'	9.25	1.1	0.35	485.35	89.031	1198.205	1772.58	174.21
SF 3	27.5	1.1	0.35	1442.93	264.687	3099.255	4806.87	158.90
SF 4	5	1.1	0.35	262.35	48.125	693.515	1003.99	182.54
SF 4'	5	1.1	0.35	262.35	48.125	698.440	1008.92	183.44
SF 5	13.6	1.3	0.35	843.34	154.7	2675.865	3673.90	207.80
SF 6	27.5	1.1	0.35	1442.93	264.687	2656.620	4364.23	144.27

## Chapter VI. Study of the infrastructure

<b>SF 7</b>	7.1	1.1	0.35	372.54	68.337	1039.005	1479.88	189.49
<b>SF 7'</b>	7.1	1.1	0.35	372.54	68.3375	1038.83	1479.70	189.46
<b>SF 8</b>	7.1	1.1	0.35	372.54	68.3375	897.81	1338.68	171.41
<b>SF 8'</b>	7.1	1.1	0.35	372.54	68.3375	899.025	1339.90	171.56

**Table VI-2: The SLS verification in longitudinal direction**

	<b>L [m]</b>	<b>B [m]</b>	<b>h [m]</b>	<b>weight of the soil [kN]</b>	<b>Dead weight of footing [kN]</b>	<b>Vertical load [kN]</b>	<b>Total load [kN]</b>	<b>service stress [kN/m<sup>2</sup>]</b>
<b>SF A</b>	9.55	1.00	0.45	438.35	107.43	1074.33	1620.11	169.65
<b>SF C</b>	21.8	1.00	0.45	1000.62	245.25	2799.89	4045.76	185.59
<b>SF D</b>	21.8	1.00	0.45	1000.62	245.25	2429.31	3675.19	168.59
<b>SF E</b>	8	1.00	0.45	367.20	90	643.38	1100.58	137.57
<b>SF E'</b>	7.55	1.00	0.45	346.55	84.93	675.81	1107.29	146.66
<b>SF F</b>	9.55	1.00	0.45	438.35	107.43	675.81	1221.59	127.92

### ✓ Results analysis:

According to the table, the service stress calculated is less than the permissible stress in both directions ( $\bar{\sigma}_s = 220 \text{ kN/m}^2$ ). Hence, the value of the width B is adopted for the calculation of the crossed continuous footing.

### VI.3.2 Verification of overturning stability

According to article 10.1.5. of RPA99/2003, whatever the type of foundation, it must be checked that the eccentricity of the resultant of the vertical gravitational forces and the seismic forces remains within the central half of the base of the foundation elements resistant to overturning.

Therefore:

$$e = \frac{M}{N} \leq \frac{B}{4}$$

With,

e: largest eccentricity due to seismic loads

M: overturning moment due to seismic forces

N: normal force of the structure

B: width of the footing

The table below provides a summary of the results obtained from the checks conducted in both the transverse and longitudinal directions for continuous footing 1.

**Table VI-3: Overturn verification in transversal and longitudinal directions**

<b>Longitudinal direction</b>	
Eccentricity (m)	0.46
L/4	1.78
$e_x < L/4 \rightarrow$ Condition checked	
<b>Transversal direction</b>	
Eccentricity (m)	0.006
B/4	0.33
$e_y < B/4 \rightarrow$ Condition checked	

### **VI.3.3 Footing reinforcement**

#### **a) Main reinforcement**

The reinforcement is calculated using the strut-and-tie method at the ultimate limit state, for one linear meter. We have:

$$A_s = \frac{N_u (B-b)}{8 \times d \times \sigma_s}$$

With,

$N_u$ : normal load distributed at ULS

- Example of calculation for continuous footing 1 in the transversal direction:

$$N_u = 1810.27 \text{ kN}$$

B: width of footing = 1.10 m

L: length of footing = 7.1 m

b: width of column = 0.45m

d: useful height:  $0.9 \times h = 0.9 \times 0.35 = 0.32$  m

$\sigma_s = 434$  MPa

Therefore:

$$A_s = \frac{1649.95 \times (1.10 - 0.45)}{8 \times 0.9 \times 0.35 \times 434 \times 7.10} = 1.38 \text{ cm}^2/\text{ml}$$

We adopt **7HA12/ml** for 15 cm of spacing between each bar.

### ✓ Length of bars:

The anchorage of the bars is given by the following formula:

$$f_{c28} = 25\text{MPa} \quad \longrightarrow \quad \frac{l_s}{\phi} = 44.1 \text{ So, } l_s = 44.1 \times 1.4 = 61.74 \text{ cm}$$

Fe E 500

In addition, we have  $B/4 = 1.50/4 = 37.5$  cm

Therefore,  $l_s > B/4$ , so brackets are necessary.

### b) Distribution reinforcement

The main reinforcements are completed by longitudinal distribution reinforcements whose total cross-section over the width B is:

$$A_r = \frac{A_s \times B}{4}$$
$$A_r = \frac{1.38 \times 1.10}{4} = 0.38 \text{ cm}^2$$

We adopt **6HA12** for 20 cm of spacing between each bar.

### c) Reinforcement diagram

The reinforcements are shown in the figure below.

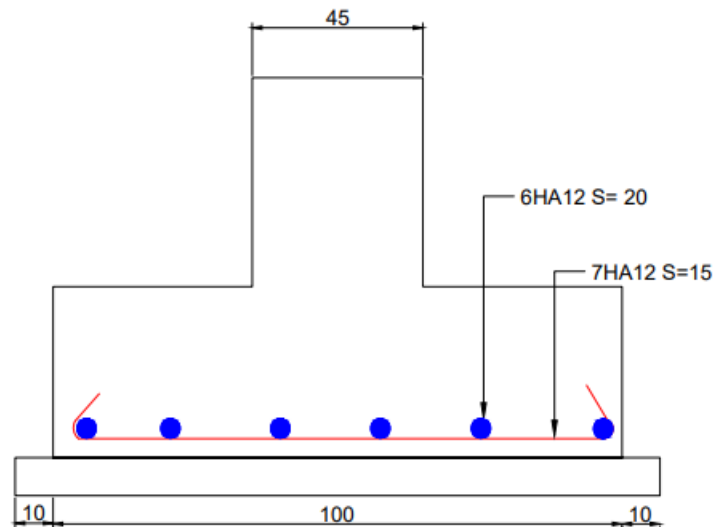

Figure VI-3: Reinforcement diagram for the strip footing 1

The following table summarizes the sections of reinforcement calculated for all the strip footings.

Table VI-4: Main and distribution reinforcement in transversal direction

	A [m]	B [m]	$N_u$ [kN]	$A_s$ [cm <sup>2</sup> ]	Choice of bars	$A_r$ [cm <sup>2</sup> ]	Choice of bars
SF 1	7.1	1.1	1649.95	1.38	7HA12	0.38	6HA12
SF 1'	7.1	1.1	1649.19	1.38	7HA12	0.38	6HA12
SF 2	9.25	1.1	2280.10	1.46	7HA12	0.40	6HA12
SF 2'	9.25	1.1	2209.80	1.42	7HA12	0.39	6HA12
SF 3	27.5	1.1	5957.59	1.29	7HA12	0.35	6HA12
SF 4	5	1.1	1260.19	1.50	7HA12	0.41	6HA12
SF 4'	5	1.1	1266.98	1.51	7HA12	0.41	6HA12
SF 5	13.6	1.3	4659.62	2.66	7HA12	0.87	6HA12
SF 6	27.5	1.1	5338.86	1.15	7HA12	0.32	6HA12
SF 7	7.1	1.1	1859.47	1.56	7HA12	0.43	6HA12
SF 7'	7.1	1.1	1859.24	1.56	7HA12	0.43	6HA12
SF 8	7.1	1.1	1664.07	1.39	7HA12	0.38	6HA12
SF 8'	7.1	1.1	1665.74	1.39	7HA12	0.38	6HA12

**Table VI-5: Main and distribution reinforcement in longitudinal direction**

	A [m]	B [m]	N <sub>u</sub> [kN]	A <sub>s</sub> [cm <sup>2</sup> ]	A <sub>r</sub> [cm <sup>2</sup> ]	Choice of bars
<b>SF A</b>	9.55	1.00	2006.52	1.03	0.26	7HA12 s = 15cm
<b>SF C</b>	21.8	1.00	5055.25	1.13	0.28	7HA12 s = 15cm
<b>SF D</b>	21.8	1.00	4555.16	1.02	0.26	7HA12 s = 15cm
<b>SF E</b>	8	1.00	1329.17	0.81	0.20	7HA12 s = 15cm
<b>SF E'</b>	7.55	1.00	1350.07	0.88	0.22	7HA12 s = 15cm
<b>SF F</b>	9.55	1.00	2313.14	1.18	0.30	7HA12 s = 15cm

### VI.3.4 Study of the rib

A rib in a continuous footing is a structural element integrated along the length of the footing. It allows loads from walls and columns to be distributed more effectively over a larger area of the footing and reduces the risk of deformation or differential settlement.

#### a) Rib dimension

To study the stiffness of the rib we use the theory of the beam on elastic soil.

#### - Stiffness condition:

$$L_{\max} \leq \frac{\pi}{2} \times L_e$$

With,

$$L_e: \text{elastic length, } L_e = \sqrt[4]{\frac{4 \times E \times I}{K \times b}}$$

L<sub>max</sub> : maximum length between column

E: Young's modulus

K: Coefficient of stiffness of the soil (according to the soil report), K = 4.4 kg/cm<sup>3</sup>

I: moment of inertia of the beam, I = bh<sup>3</sup>/12

$$h \geq \sqrt[3]{\frac{48 \times K \times L^4}{E \times \pi^4}} = \sqrt[3]{\frac{48 \times 440 \times 4.15^4}{2 \times 10^5 \times \pi^4}} = 0.70 \text{ m}$$

We adopt  $h = 90$  cm and  $b = 45$  cm

Therefore,

$$L_e = \sqrt[4]{\frac{4 \times 2 \times 10^5 \times 0.03}{440 \times 0.45}} = 3.33 \text{ m}$$

$$L_{\max} = 4.15 \text{ m} < \frac{\pi}{2} \times L_e = 5.21 \text{ m} \rightarrow \text{Condition checked}$$

### b) Verification of non-punching

According to article A.5.2.2.2 of the CBA93:

$$N_u \leq 0.045 \times \mu_c \times h \times \frac{f_{c28}}{\gamma_b}$$

With,

$$N_u: \text{Normal force at the ULS of the most stressed column} \rightarrow N_u = 1838.75 \text{ kN}$$

$\mu_c$ : Perimeter of the contour at mid-section level

$$\mu_c = (a + b + 2 \times h) \times 2 = (0.45 + 0.45 + 2 \times 0.90) \times 2$$

$$\mu_c = 5.40 \text{ m}$$

$$N_u \leq 0.045 \times 5.40 \times 0.90 \times \frac{25}{1.15} = 4754.34 \text{ kN} \rightarrow \text{Condition checked}$$

### c) Rib reinforcement

Loads for each row of footings at the ultimate limit state:

$$Q = N/L$$

N: Total load at the ULS.

L: Length of the footing.

Using the ETABS software, the efforts obtained at the supports and spans of the ribs in each direction are illustrated in illustrated in figures VI-4 and VI-5.



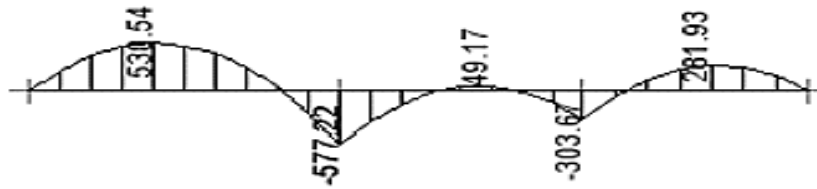

a- Bending moment

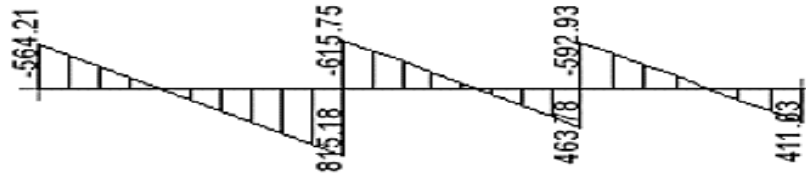

b- Shear force

Figure VI-4: Diagram of efforts in the rib in the x direction

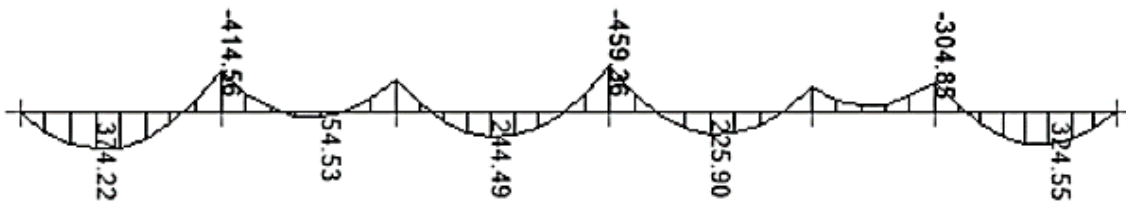

a- Bending moment

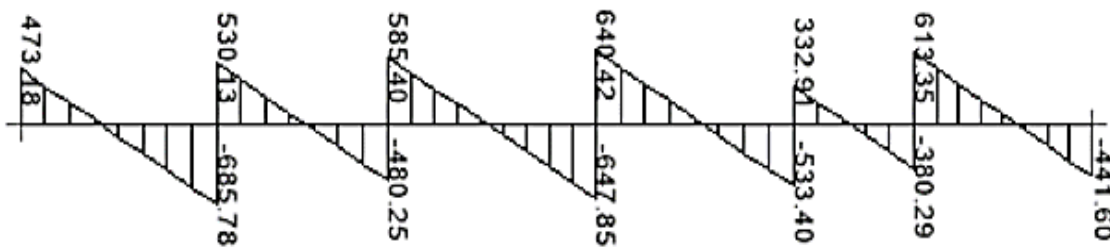

b- Shear force

Figure VI-5: Diagram of efforts in the rib in the y direction

The following table summarize the reinforcement of the beam (90×45 cm<sup>2</sup>) in both longitudinal and transversal direction.

**Table VI-6: Reinforcement of the rib beam in both directions**

<b>Direction of the footing</b>	<b>Length [m]</b>		<b>M<sub>max</sub> [kN.m]</b>	<b>A<sub>s,cal</sub> [cm<sup>2</sup>]</b>	<b>Choice of bars</b>
<b>x-x</b>	4.15	Span	530.54	15.30	8HA16 + 2 HA14
		Support	-577.22	16.78	8HA16 + 2 HA14
<b>y-y</b>	3.17	Span	374.22	11.00	8HA14
		Support	-459.36	18.17	8HA16 + 2 HA14

**d) Non-fragility condition :**

In the case of a rectangular section subjected to simple bending, the following condition must be verified:

$$A_{\min} \geq 0.23b.d \frac{f_{t28}}{f_e} = 3.52 \text{ cm}^2$$

The condition is checked.

**e) Service limit state verification**

G: center of gravity.

A<sub>sc</sub>: Compression reinforcement section.

A<sub>s</sub>: Tensile reinforcement section.

$$\sum S_{/G} = 0$$

$$\frac{b}{2} y^2 + n A_{sc} (y-d') - n A_s (d-y) = 0$$

y: distance between the neutral axis and the furthest fiber.

- **Stress evaluation :**

$$\sigma_b = \frac{M_s}{I} y \leq \bar{\sigma}_b = 0.6 f_{c28}$$

With,  $I = \frac{b}{3} y^3 + n A_{sc} (y-d)^2 + n A_s (d-y)^2$

$$\sigma_s = n \frac{M_s}{I} (d-y) \leq \bar{\sigma}_s = f_e / Y_s$$

The verification of the stress for the beam (90×45) cm<sup>2</sup> is summarized in the following table.

**Table VI-7: Verification of the stress in both directions**

Direction of the footing	M <sub>s</sub> [kN.m]	y [m]	I [m <sup>4</sup> ]	Concrete		Steel		Observation
				σ <sub>b</sub> [MPa]	σ̄ <sub>b</sub> [MPa]	σ <sub>s</sub> [MPa]	σ̄ <sub>s</sub> [MPa]	
x-x	427.50	25	0.01	10.7	18	358.60	434	Checked
y-y	340.26	25	0.01	8.50	18	285.81	434	Checked

**f) Verification of the shear force**

In accordance with article A.5.1.21 of BAEL91, the maximum tangent stress of a beam in the case of straight transverse reinforcement must verify the following condition:

$$\tau_u = \frac{V_u}{b.d} \leq \min (0.2f_{cj} / Y_b, 5\text{MPa}) = 3.33 \text{ MPa}$$

With,

V<sub>u</sub>: maximum shear force

b: beam width

d: useful height

The result of the verification is summarized in the following table.

Table VI-8: Verification of the shear stress for the rib

Beam section [cm <sup>2</sup> ]	V <sub>u</sub> [kN]	τ <sub>u</sub> [MPa]	τ̄ <sub>u</sub> [MPa]	Observation
90 × 45	815.18 (x-x)	2.23	3.33	Checked
	640.42 (y-y)	1.15	3.33	Checked

g) Reinforcement diagram

The reinforcement diagram is shown in the figure bellow.

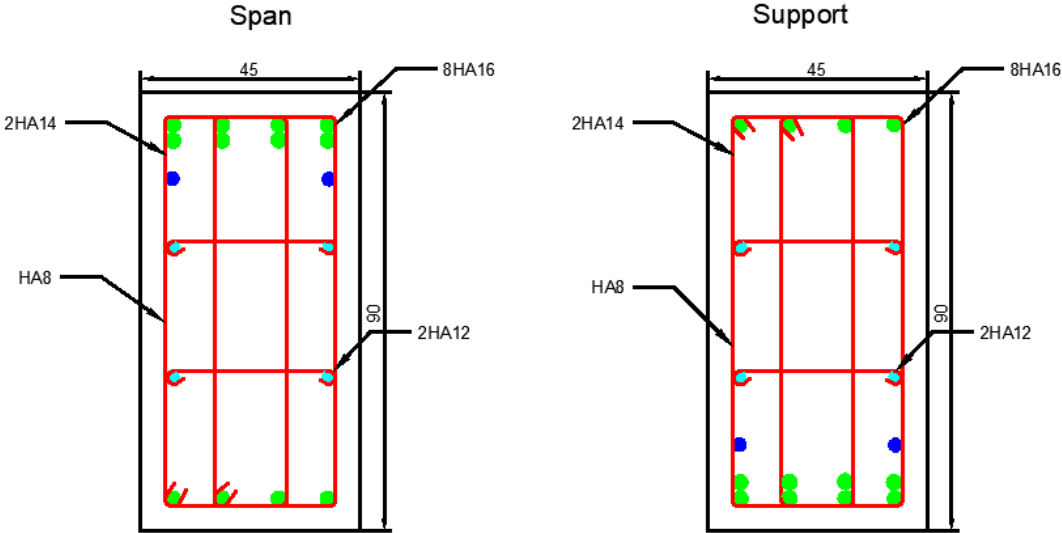

Figure VI-6: Reinforcement diagram of the rib

VI.4 Conclusion

This chapter was dedicated to the study of the infrastructure of our building according to the imposed regulations. The foundation, choice focused on cross-continuous footings, deemed the safest and most economical solution. Additionally, we studied the reinforcement for these footings and the ribs.

**Chapter VII**  
**Analysis of**  
**Buildings Pounding**

### VII.1 Introduction

Buildings in seismically active zones, such as the northern region of Algeria, are mainly exposed to earthquake. In densely populated areas such as Algiers, old buildings are constructed very close to each other with little or no gap between them. Due to earthquake-induced ground motions, these buildings begin to vibrate out of phase and can collide with each other, causing severe damage to structures, lives and the economy. Urban seismic vulnerability inspections following several major earthquakes have identified pounding as one of the main hazards for buildings.

Pounding of adjacent buildings have caused many damages that range from slight nonstructural to serious structural damage that could even lead to a total collapse of buildings. Some of the pounding incidents that have been documented include the 1971 San Fernando earthquake. The Olive View Hospital affected the outside stairway tower in this earthquake, causing significant damage and a permanent tilt to the tower. The Loma Preita earthquake of 1989 damaged about 200 structures, whereas the 1985 earthquake in Mexico City damaged nearly 40% of the city's buildings. [5]



**Figure VII-1: Examples of structural damage caused by pounding**

### VII.2 Causes of pounding

The main reason of the seismic pounding is the provision of insufficient gap or no gap in the building. The response of adjacent buildings towards external force is mainly due to following conditions:

- ✓ When the separation gap between adjacent buildings is insufficient or nonexistent.
- ✓ When buildings have sufficient gap but one or more members connect them.
- ✓ When adjacent buildings have different dynamic properties like mass, height, orientation, geometry.
- ✓ When there is eccentricity between mass and rigidity centers, which cause torsion in the structure. [6]

Pounding building scenarios can be generally categorized as either slab-to-slab collision (floor-to-floor) or slab-to-column collision (floor-to-column) as shown in figure VII-2. The first case is observed when the colliding buildings have the same floor height, while the second case occurs when the buildings have different floor heights. [7]

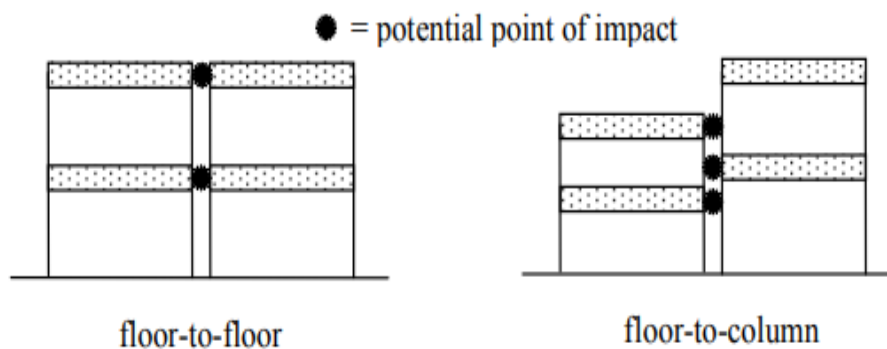

Figure VII-2: Pounding categorization[7]

The objective of this chapter is to analyze the several factors that affect the seismic joint.

### VII.3 Dimensions of the seismic joint

In order to reduce inter-structural interaction or collision, the calculation codes of the various countries, as well as the Algerian parasismic regulations, require a seismic joint, as

presented in the figure below. An element that separates two neighboring blocks whose minimum width  $d_{\min}$  must meet the following condition:

$$d_{\min} = 15 \text{ mm} + (\delta_1 + \delta_2) \text{ mm} \geq 40 \text{ mm}$$

Where,

$\delta_1$  et  $\delta_2$  : maximum displacement of the two blocks.

$$\delta_k = R \times \delta_{ek}$$

$\delta_{ek}$  : Displacement due to seismic forces  $F_i$  (including torsional force).

R : behavior coefficient.

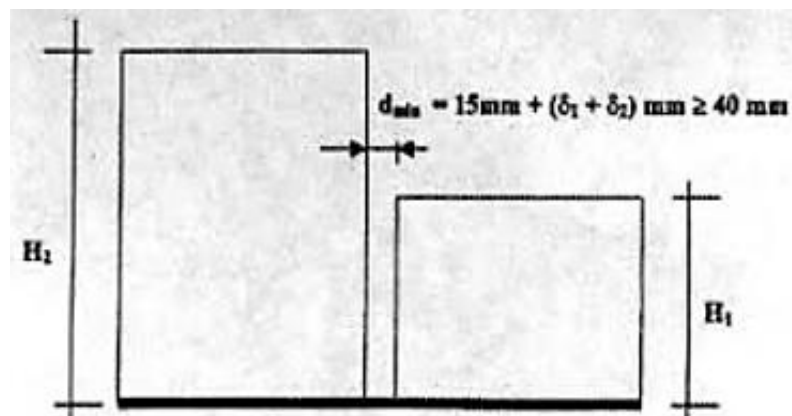

Figure VII-3: Minimum width of the seismic joint in accordance with RPA99/2003

### VII.4 Methodology

#### VII.4.1 Brief description of study buildings

In the first part of this study, the structure analyzed is adjacent to a similar building, separated by a minimum distance of 10 cm. The main objective is to examine the effects of



collisions between the two buildings. To do this, several parameters were taken into account, such as the total height of the buildings and the type of bracing used.

Using the ETABS program, the 3D modelling of building and analysis of the interaction were carried out, this software can be used to accurately simulate structural behavior and identify critical points where impacts may occur.

The following cases were adopted for our study:

- Identical structure model: Two buildings with the same floor plan, the same storey height, the same material characteristics, and the same element sections. As illustrated in the figure below.

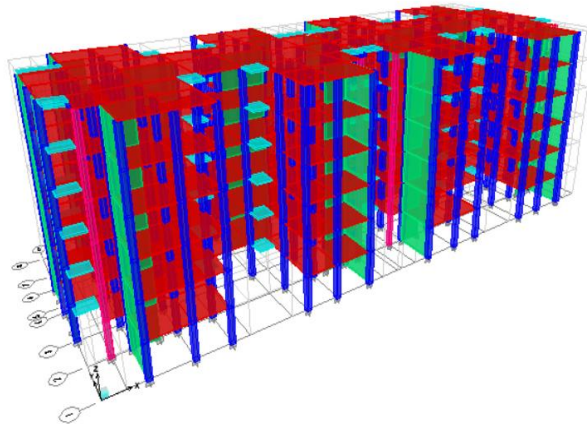

**Figure VII-4: Building model 1**

- Height variation model: Two buildings with the same floor plan, the same storey height, the same material characteristics, and the same element sections but different overall heights: the change in the overall height can cause variations in the basic vibration period and, consequently, the seismic response. As illustrated in the figure below.

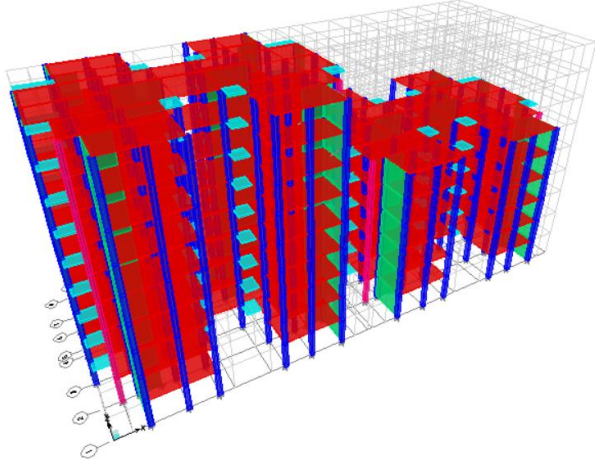

Figure VII-5: Building model 2

- Bracing variation model: Two buildings with the same floor plan, the same storey height, the same material characteristics, and the same element sections but different types of bracing: this approach studies the effect of changing the type of bracing on building interactions and seismic response. As illustrated in the figure below.

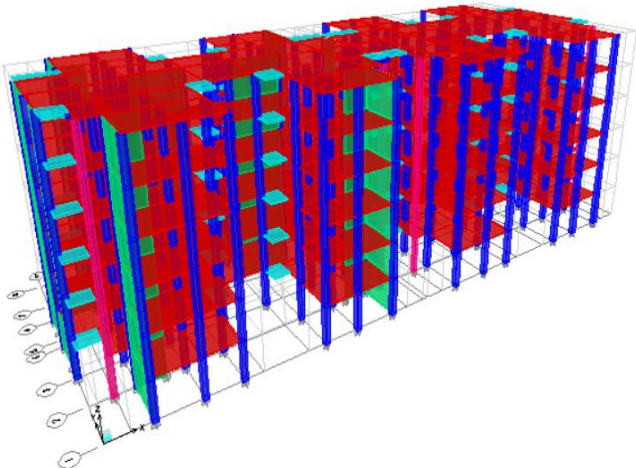

Figure VII-6: Building model 3

Using these three configurations, we can carry out an exhaustive analysis of the effects of structural variations on the collision of buildings and propose solutions to minimize the risk of collision.

**VII.4.2 Different models of pounding**

Given the complexity of the pounding phenomenon, research has predominantly focused on two analytical modeling, the contact element method and the streomechanical approach. In the former approach, adjacent buildings are typically represented by masses, and the pounding between these masses is simulated using contact or gap elements. These gap elements activate upon collision of the masses and deactivate when the masses move apart. A brief summary of the various modeling methodologies is provided here below.

- **Linear spring model**

In this model, as shown in figure VII-7a, a linear elastic spring was used to stimulate the contact element between adjacent structures, it is assumed to have a characteristic pull force only when the initial gap between the buildings is less than relative gap between them. At that point, the spring contracts and generates forces that allow the pounding phenomenon to be taken into consideration.

- **Model of kevin-Voight**

This model is represented by a linear spring in parallel with a shock absorber as shown in figure VII-7b, the importance of the shock absorber is that, it takes the effect of energy dissipation during collision.

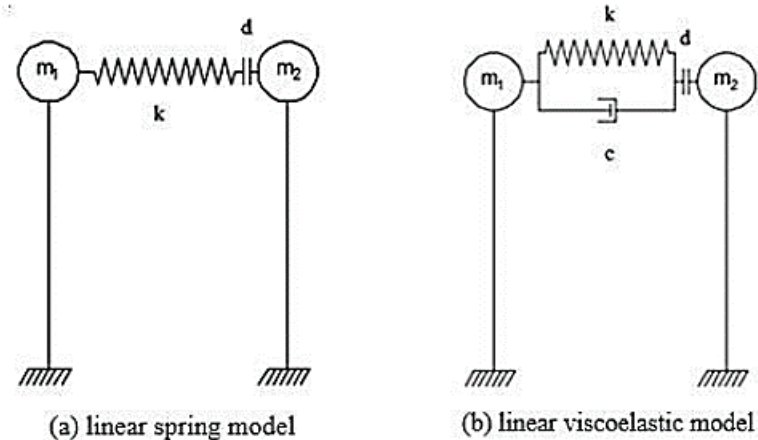

**Figure VII-7 : Different models of pounding**

However, the streomechanical model modify the velocities of the colliding bodies after impact by using momentum balance and restitution coefficient, this approach is hardly implanted in software and is no longer valid if the impact duration is large enough for changes to occur in the configuration of the system. in our study we will adopt the first approach.[8]

### VII.4.3 Properties of gap element

The gap element is a non-linear element with two important parameters: stiffness and opening. It works only in compression and is used to connect two adjacent nodes to model contact as illustrated in figure below. When two buildings collide, the gap element is used to assess the extent of the collision. [9]



**Figure VII-8 : Gap element**

The following criteria was considered for the gap element:

- Stiffness: this value is set high to avoid overlapping between adjacent buildings.
- Opening : is the separation distance between two adjacent building, it must be zero or positive.

This element was modeled using a gap link element that connects two nodes from two buildings at each floor, as illustrated in figure VII-9, in order to account the contact force between them.

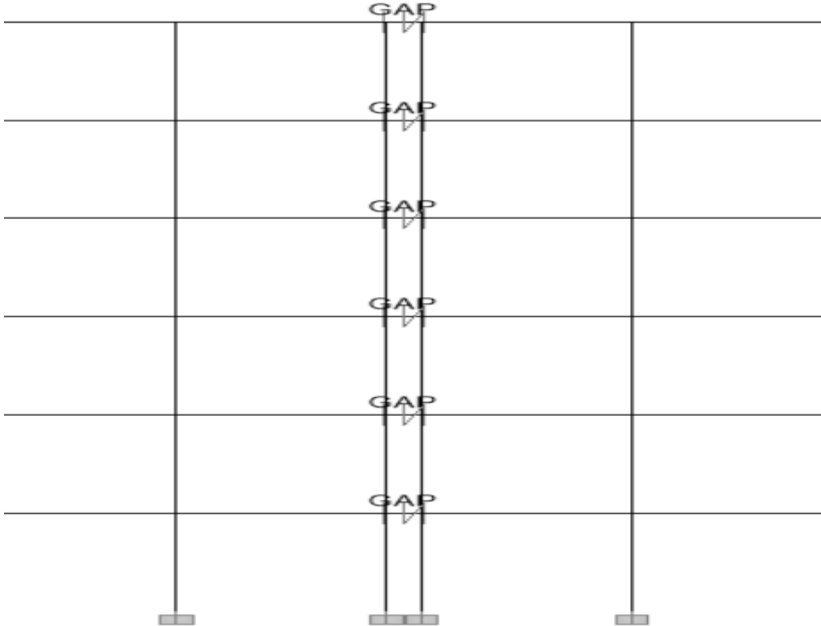

Figure VII-9 : Modelling of gaps

**VII.4.4 Seismic loads**

In order to analyze the behavior of the structure with regards to dynamic loads, namely the seismic loads, several methods have been advocated and these are applicable to the static or dynamic case, depending on the needs of the study, can be classified into 02 major categories: Linear methods and non-linear methods.

Typically, response spectrum analysis or comparable lateral static loads are used in linear analysis to carry out seismic design for the majority of conventional structures. However, in certain situations, such as those involving irregular, extremely ductile, critical, or higher modes-induced structures, linear analysis is unable to estimate the maximum response of the structures; in these situations, a time-integration approach is thought to be more suitable. Non-linear time history analysis is necessary for a comprehensive seismic design of buildings.

**- Non-Linear Temporal Analysis**

The determination of temporal seismic loads can be carried out using different approaches, and these seismic loads can be described either by real accelerations recorded in the field (real accelerograms) or by artificially constructed accelerations. In our study, time history data of El-Centro earthquake having peak ground acceleration (PGA) of 0.3145 at 2 second is taken.

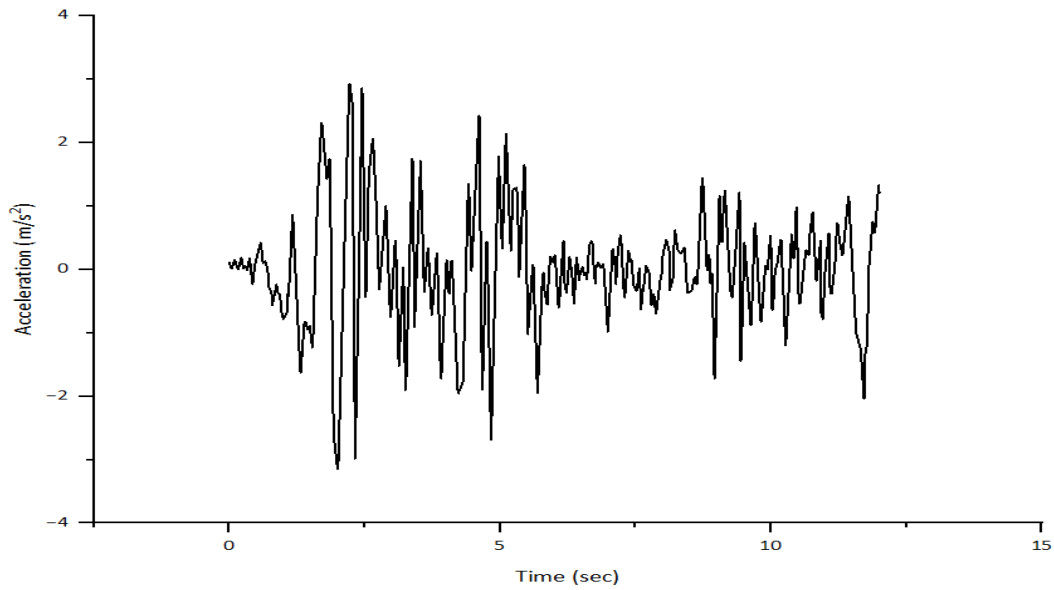

**Figure VII-10: Time history plot of El-centro earthquake**

### **VII.5 Results and discussion**

#### **- Pounding force :**

For each of our 03 cases, the pounding force is estimated under various gap distances such as  $G = 10, 30,$  and  $50\text{mm}$ , in addition to in contact adjacent building,  $G = \text{zero}$ , under the El-Centro earthquake ground motion. The results of each case will be presented and discussed in the following section.

**- Case 1**

We consider 02 adjacent R+5 reinforced concrete buildings, with a total height of 18.36m each, and a storey height of 3.06m. Non-linear time analysis allows us to estimate the maximum pounding force. The measurement nodes are those at the top (N1 and N2).

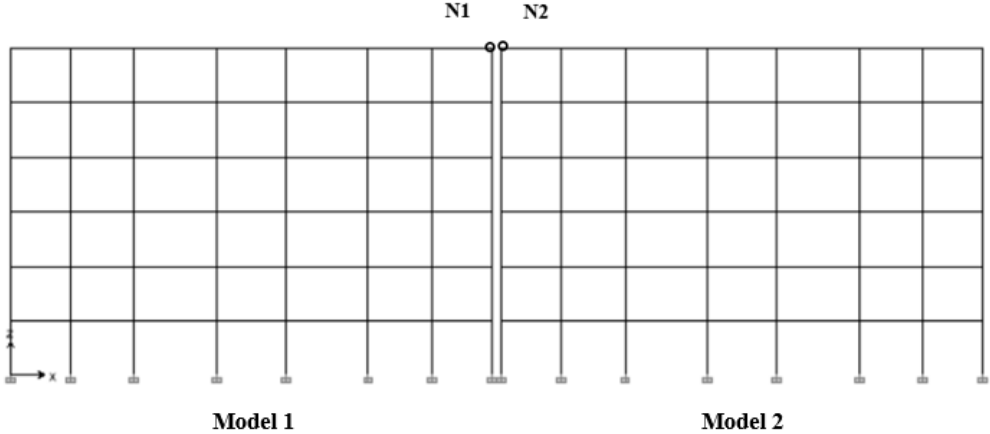

The fundamental periods of the two buildings are given in the following table.

**Table VII-1: The Fundamental periods with the modal mass participation**

	<b>Fundamental period [s]</b>	<b>Modal mass participation [%]</b>
<b>Building model 1</b>	0.432	89.981
<b>Building model 2</b>	0.432	89.982

The two structures have the same period, they vibrate in phase, therefore, no collision between the two structures was observed for gaps 10, 30 and 50 mm, the force of the spring is equal to zero, except when there is no separation distance ( $G = 0$ ).

The displacements of the two nodes at the top of the two buildings are summarized in the following table.

**Table VII-2: The Displacements of the two nodes with and without pounding**

		<b>Without pounding</b>	<b>With pounding</b>
<b>Displ of node 1 [mm]</b>	<b>Max(+)</b>	98.40	98.41
	<b>Min(-)</b>	96	96
<b>Displ of node 2 [mm]</b>	<b>Max(+)</b>	98.30	98.31
	<b>Min(-)</b>	95.80	95.82

The figures VII-11 and VII-12 show the variation of the node displacements with and without pounding.

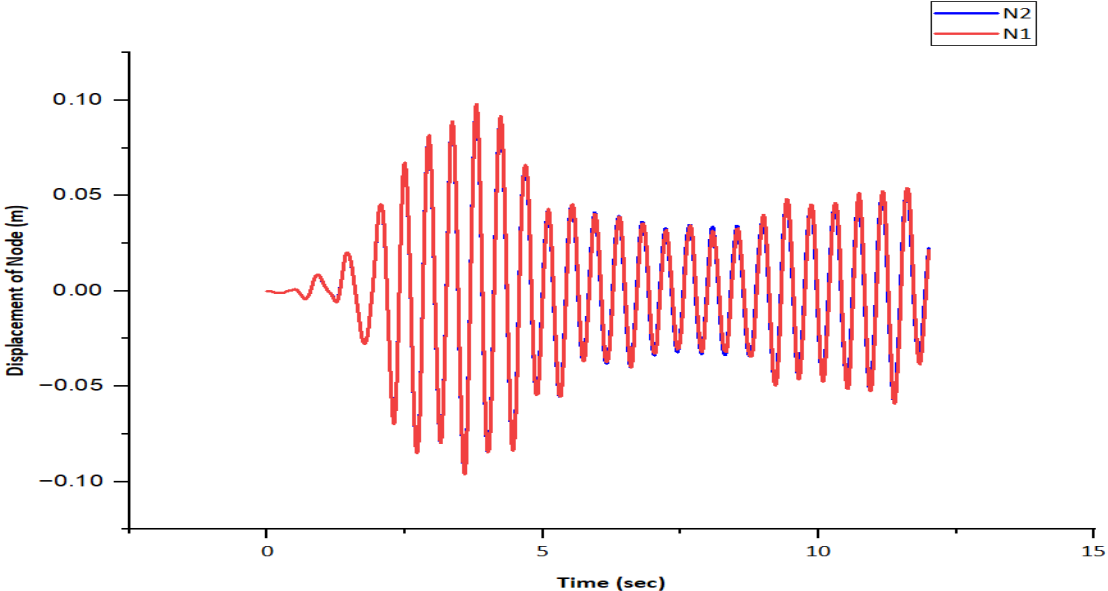

Figure VII-11: Time displacements graph of nodes without pounding

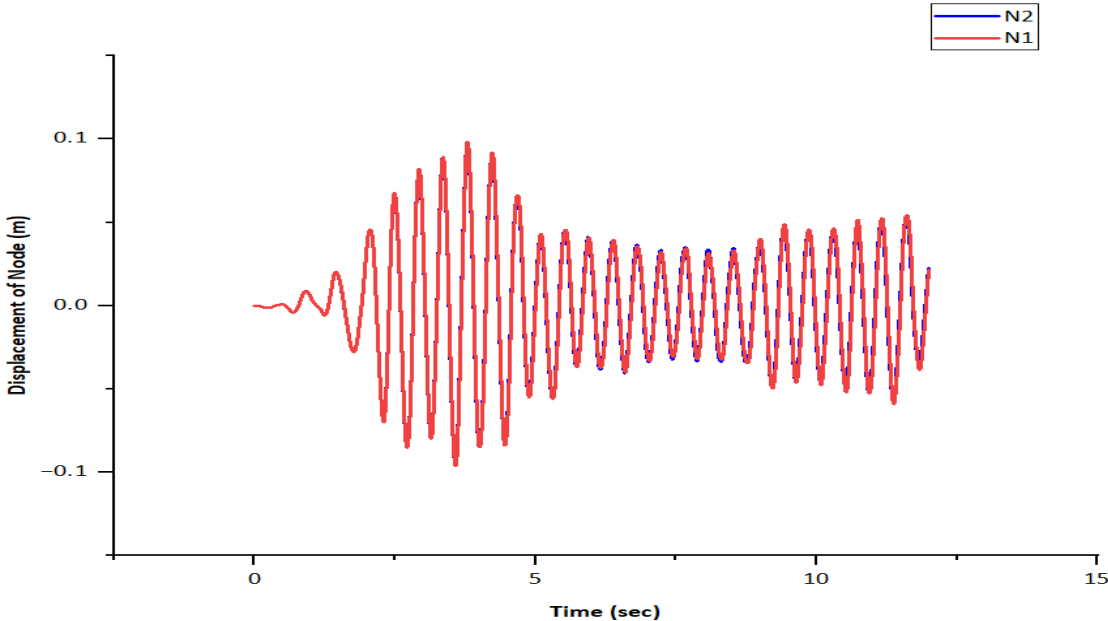

Figure VII-12: Time displacements graph of nodes with pounding

According to the figures, the displacement of both nodes is the same with and without pounding. This can be explained by the similar periods of the two buildings.



The following figure show the pounding force for gap zero.

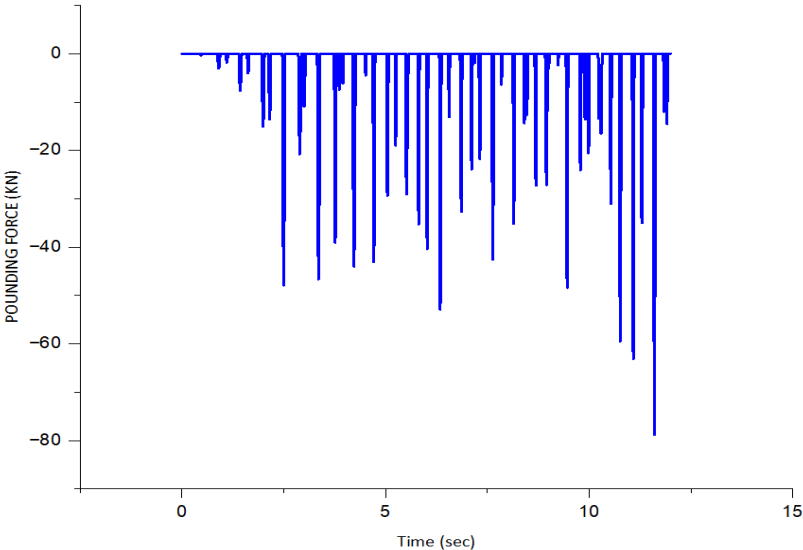
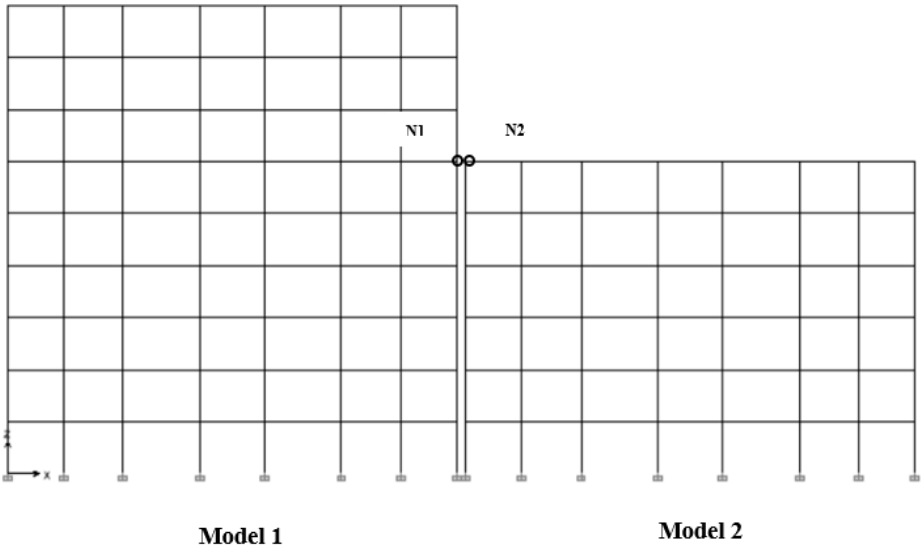

Figure VII-13: Pounding force for gap 0 mm

- Case 2 :

We consider 02 adjacent R+5 reinforced concrete buildings, each with a storey height of 3.06m. The left building has a total height of 27.54m and the right of 18.36m. The measurement nodes are N1 and N2 as shown below.



The fundamental periods of the two buildings are given in the following table.

**Table VII-3: The Fundamental periods with the modal mass participation**

	<b>Fundamental period [s]</b>	<b>Modal mass participation [%]</b>
<b>Building model 1</b>	0.737	92.076
<b>Building model 2</b>	0.523	89.021

The fundamental period of lower height building is smaller than that of higher height building. As the height of the building increases, it becomes more flexible and the overall rigidity decreases, which explains the increase in the fundamental period of model 1.

The displacements of the two nodes at the top of the two buildings are summarised in the following table.

**Table VII-4: The Displacements of the two nodes with and without pounding**

		<b>Without pounding</b>	<b>With pounding</b>
<b>Displ of node 1 [mm]</b>	<b>Max(+)</b>	128	68
	<b>Min(-)</b>	111	65
<b>Displ of node 2 [mm]</b>	<b>Max(+)</b>	105	67
	<b>Min(-)</b>	110	104

The figures below the variation of the node displacements with and without pounding

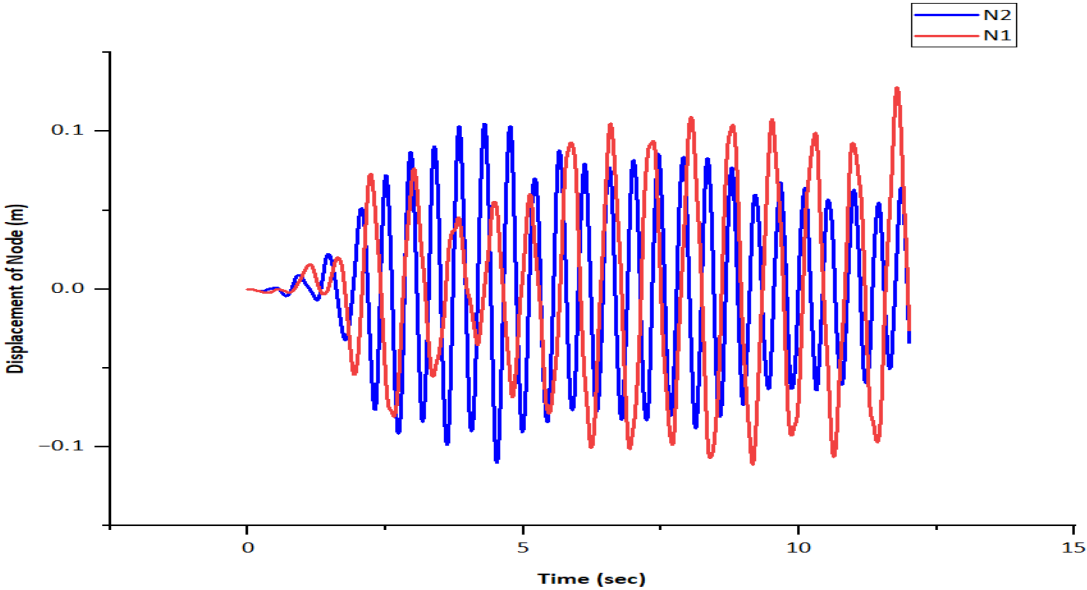

**Figure VII-14: Time displacements graph of Nodes without Pounding**

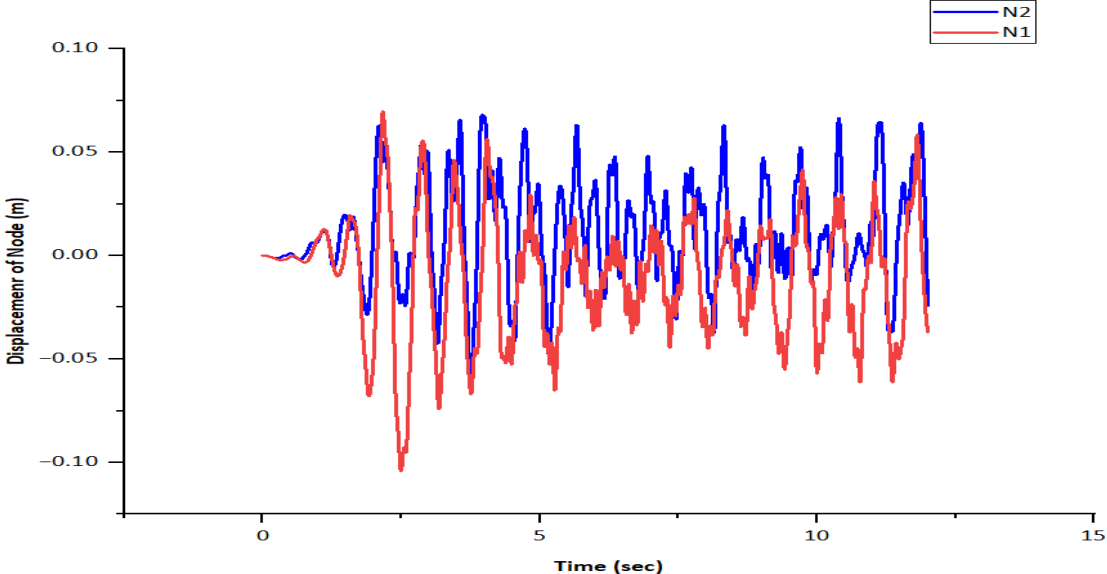

Figure VII-15: Time displacements graph of Nodes with Pounding

The maximum pounding force for each floor for zero, 10, 30 and 50mm separation distance under El-Centro earthquake ground motion is shown in figure bellow.

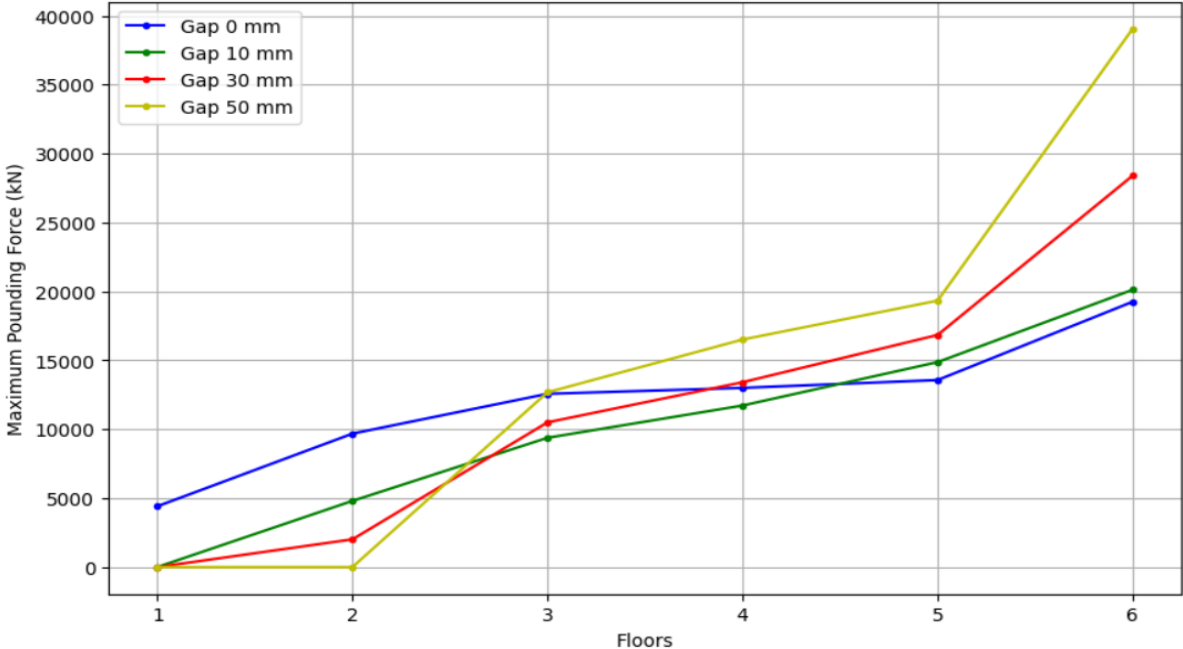

Figure VII-16: Distribution of Maximum Pounding Force on various Floors

Maximum pounding force was observed at the top floor (5th) under the ElCentro earthquake ground motion. The pounding force increased as the gap distance increased but the impact forces were less numerous as illustrated in figure VII-17. No pounding force was observed on the first and second floors for a gap of 50mm, therefore the pounding force increased until it stopped.

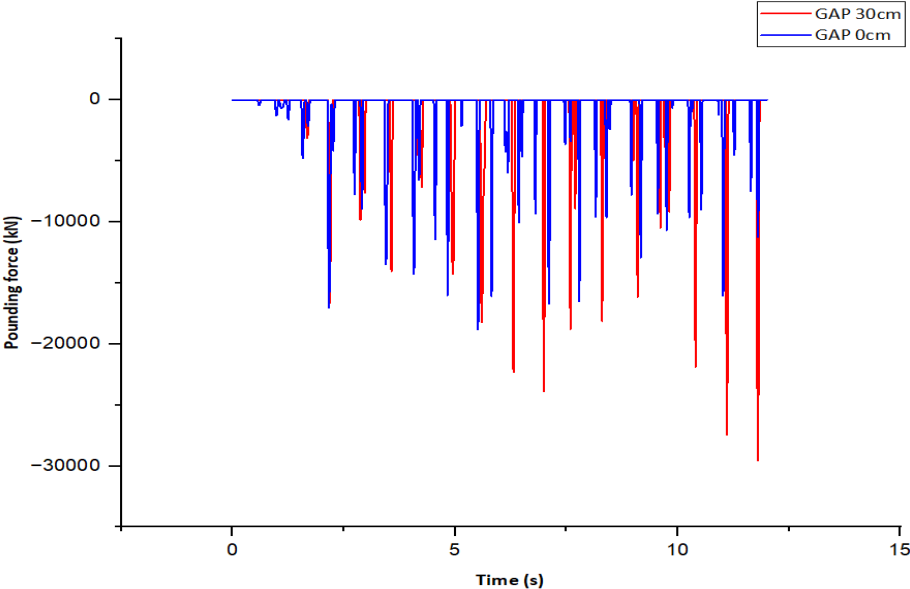

Figure VII-17: Pounding force for with gap distances 0 mm and 30mm

Pounding occurs between two moving masses with different velocities,  $V_1$  and  $V_2$ , moving in opposite directions, this phenomenon is closely dependent on the gap size, however an increase of the gap opening does not indicate a reduction in the velocities of the 2 masses and therefore, it does not reduce the pounding force. Knowing that the latter is linked to the quantity of movement of each mass. The following figures illustrate the difference in velocity for nodes 1 and 2 with different gap opening.

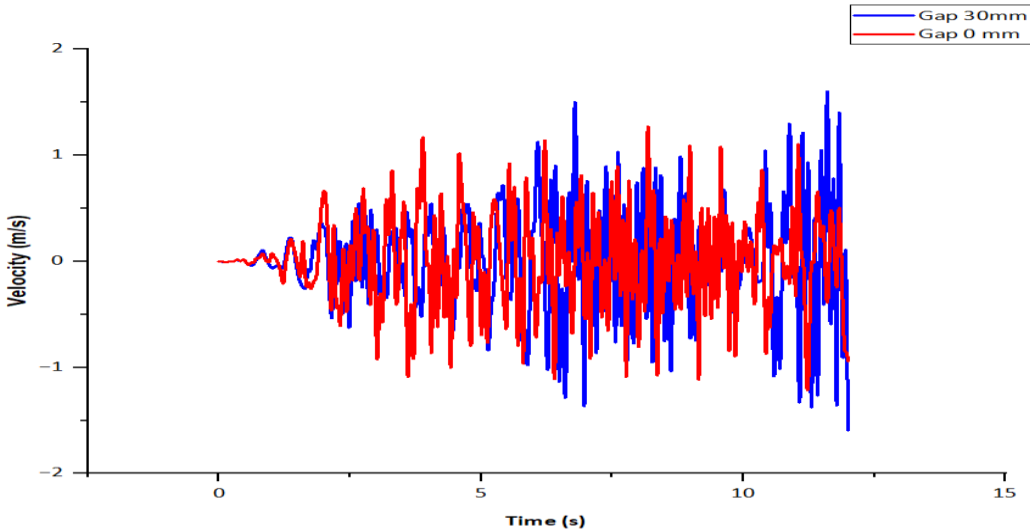

Figure VII-18: Velocity graph for node 2 with gap distances 0 mm and 30mm

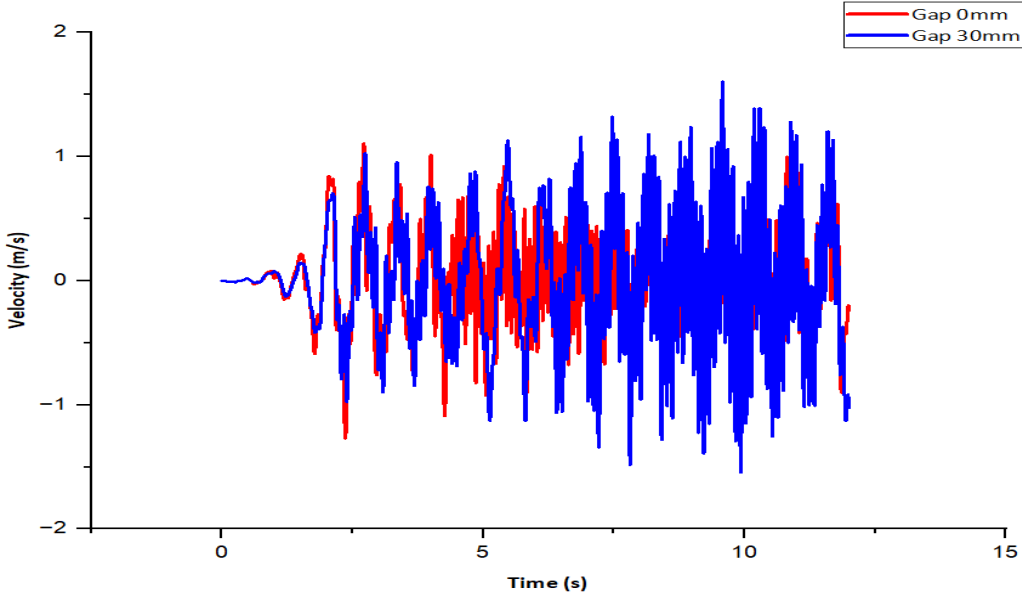

Figure VII-19: Velocity graph for node 1 with gap distances 0 mm and 30mm

- **Case 3 :**

We consider 02 adjacent buildings with a total height of 18.36m each, and a storey height of 3.06m. The building on the left, unlike the one on the right, has bracing walls. The measurement nodes are those at the top (N1 and N2).

The fundamental periods of the two buildings are given in the following table.

**Table VII-5: The Fundamental periods with the modal mass participation**

	<b>Fundamental period [s]</b>	<b>Modal mass participation [%]</b>
<b>Building model 1</b>	0.444	91.110
<b>Building model 2</b>	0.669	93.110

Comparing the periods of the two models, we see that the absence of shear walls in model 2 increases the fundamental period because the overall rigidity has decreased.

The displacements of the two nodes at the top of the two buildings are summarized in the following table.

**Table VII-6: The Displacements of the two nodes with and without pounding**

		<b>Without pounding</b>	<b>With pounding</b>
<b>Displ of node 1 [mm]</b>	<b>Max(+)</b>	106	160.80
	<b>Min(-)</b>	103	162.40
<b>Displ of node 2 [mm]</b>	<b>Max(+)</b>	135	267.50
	<b>Min(-)</b>	132	196

The figures below show the variation of the node displacements with and without pounding.

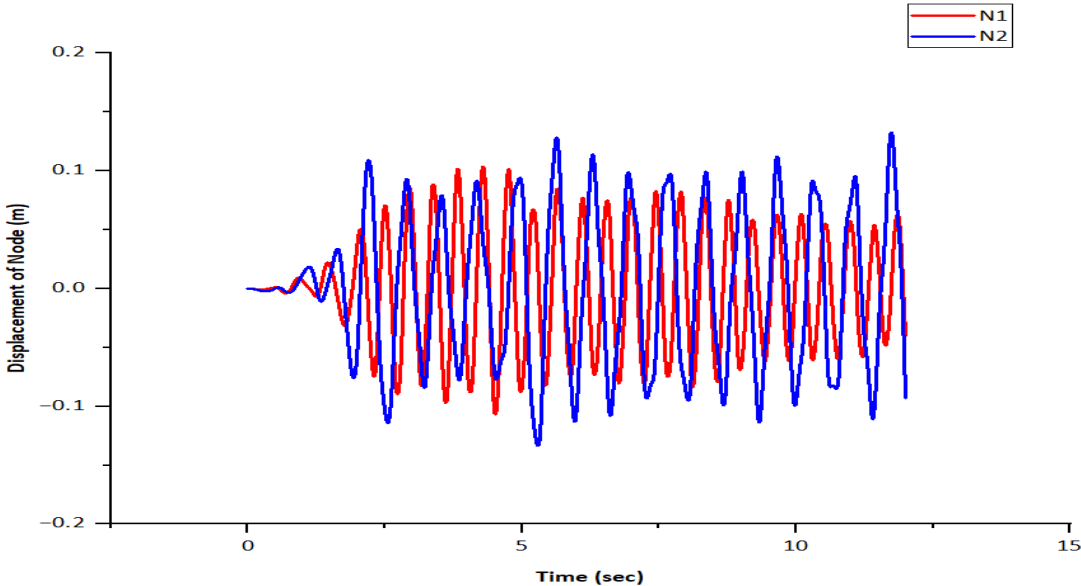

Figure VII-20: Time displacements graph of nodes without pounding

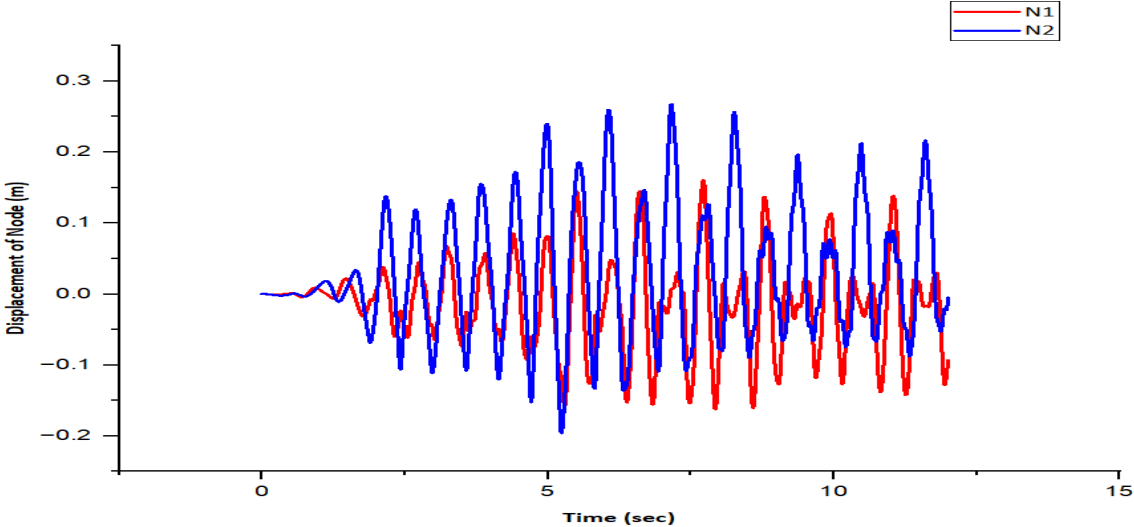

Figure VII-21: Time displacements graph of nodes with pounding

Comparing the results, we can observe that the displacement of the nodes with and without pounding is greater than that of the nodes with walls. This is because the latter is more rigid, and the displacement of the nodes increases when there is pounding.

The maximum pounding force for each floor for zero, 10, 30 and 50mm separation distance under El-Centro earthquake ground motion is shown in the following figure.

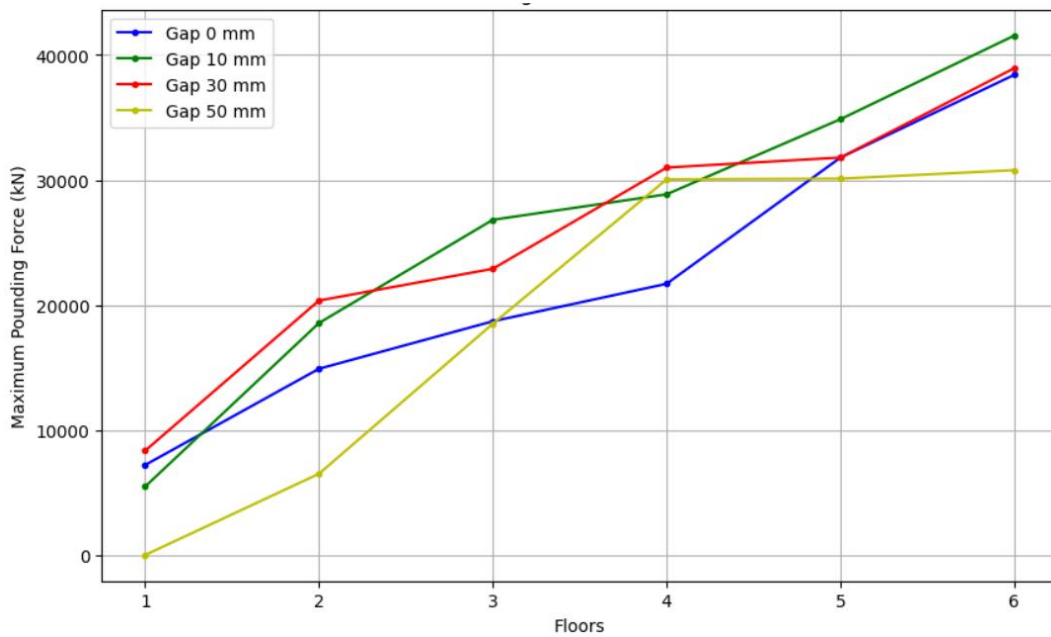

Figure VII-22: Distribution of maximum pounding force on various floors

Similar to case 2, the maximum pounding force was observed at the top floor (5th) under the El-Centro earthquake ground motion. The pounding force decreased as the gap distance increased from 10 to 50mm, so the force is inversely proportional to the separation distance in this case. No pounding force was observed on the first floor for a gap of 50mm. the pounding force for separation of 0 and 30cm is illustrated in figure below.

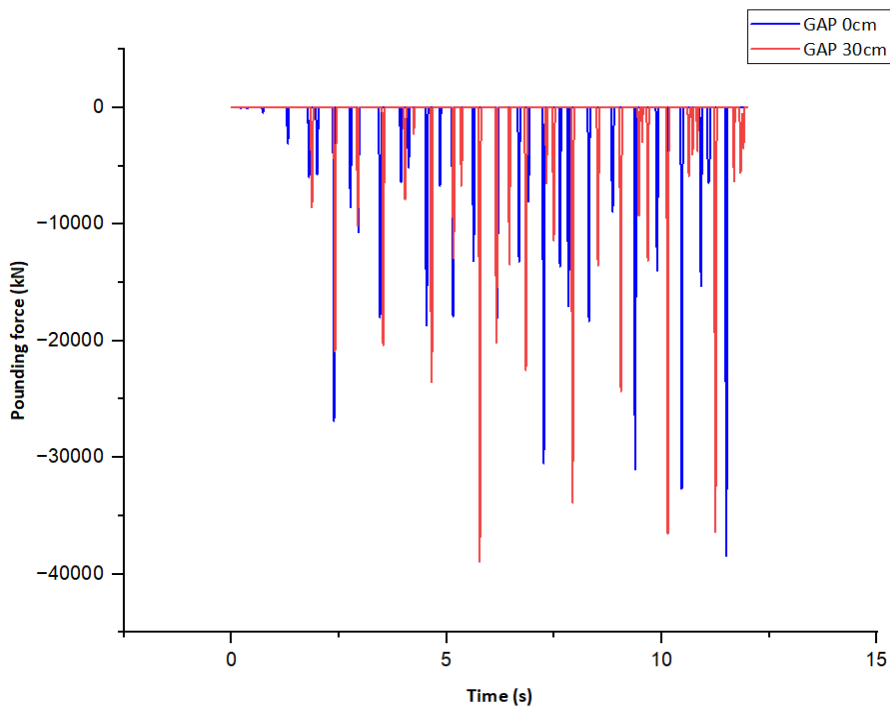

Figure VII-23: Pounding force for gap 0 and 30mm



### VII.6 Mitigation of pounding

The results obtained from the three cases studied have shown that the pounding of adjacent buildings is influenced by several parameters. In order to minimize the effect of this phenomenon, various mitigation techniques can be used:

- Providing additional strength by adding shear walls can reduce lateral displacement by increasing the building's rigidity.
- Providing sufficient minimum distance between adjacent building.
- Structure with regular geometry and uniformly distributed mass and stiffness, both in plan and elevation, are less affected by pounding.
- Adding dimper element, which absorb and dissipate seismic energy.
- Elastic element placed between already constructed buildings can protect them from the effect of pounding. [6] [10]

### VII.7 Conclusion

In this chapter, the study of pounding has been carried out for three finite element modeling cases using non-linear time analysis. We derive the following conclusions from the observations:

- Pounding occurs when the width of the gap does not absorb the sum of the displacements of the adjacent buildings.
- All models have shown an amplified response for the top floor.
- The opening of the gap influences the amount of impact, which is linked to the response of the structure, particularly the time, the distance separating the two buildings, and the velocity of the structures. [6] [10]

For future studies, it would be interesting to study the torional behaviour of structures, as well the analytical impact models used to analyse pounding.

# **Conclusion**

## General conclusion

---

The primary objective of this thesis is to establish a detailed study of reinforced concrete building with a ground floor and five additional levels, as part of the 200 housing AADL project in Khemis El Khachena, a region classified as a moderate seismic zone. The study included a comprehensive analysis of various parameter that effect the pounding phenomenon

In the first part of the thesis, project presentation was provided to familiarize us with the project site, including the soil investigation, as well as the geometrical characteristics of the building, including its dimensions. Additionally, the properties of the materials used were discussed, specifically concrete and steel. The geotechnical report made by the national laboratory of housing and construction was thoroughly analyzed to inform foundation design and mitigate any risks associated with soil behavior.

Calculating the reinforcement of the primary elements required finite element (FE) modelling of the building in order to obtain the results of the solicitations to which the superstructure elements, such as beams, columns and walls, are subjected. In addition, the infrastructure elements like the foundation. The ETABS software was therefore selected for the purpose enabling us to make a rigorous calculation and to adopt reinforcement sections that meets the requirements of the Algerian construction standards and regulations, namely RPA99/2003, BAEL 91 modified 99 and CBA93. A seismic analysis followed by the necessary verification was conducted, ensuring the overall structural stability.

In the second part of the thesis, analysis of the three cases of pounding between adjacent buildings using gap element for nonlinear temporal analysis, revealed the different parameters influence the phenomenon leading to various degrees of damages. The first case showed that two buildings with similar periods would give similar displacements with or without collision. However, in case 2 and 3, varying the stiffness of one of the two buildings and thus varying its period, whether by increasing its total height or arranging the shear walls, resulted in changes in the displacement of the nodes, this, in turn, affected the pounding force.

This study was an enriching experience which allowed me to capitalize on my theoretical knowledge acquired during my university course, the outcome highlight the importance of the seismic joint in construction, as it reduce the risk of damage during earthquakes, this contribute to the existing knowledge of pounding buildings and established a solid foundation for future research.

# Bibliography

- [1] D.T.R. -B.C. 2.2 – Charges permanentes et charges d’exploitation.
- [2] D.T.R. -B.C. 2.41 - Règles de Conception et de Calcul des Structures en Béton Armé C.B.A.93.
- [3] D.T.R. -B.C. 2.48 - Règles parasismiques algériennes RPA99/2003.
- [4] C.S.T.B, D.T.U- Règles BAEL 91 révisées 99,2000.
- [6] V. P. Namboothiri, ‘Seismic Pounding of Adjacent Buildings’, International Research Journal of Engineering and Technology, Vol. 04, no. 03, Mar-2017
- [7] Cole, G., Dhakal, R.P., Carr, A.J., Bull, D. (2010) Building pounding state of the art: Identifying structures vulnerable to pounding damage. Wellington, NZ: 2010 New Zealand Society of Earthquake Engineerings (NZSEE) Conference, 26-28 Mar 2010.
- [8] S. Muthukumar and R. Desroches, ‘Evaluation of Impact Models for Seismic Pounding’, 13<sup>th</sup> World Conference on Earthquake Engineering, Canada, August 1-6, 2001, Paper No.235.
- [9] M. S. Masmoum and M. S. A. Alama, ‘Tying Devices to Mitigate Pounding of Adjacent Building Blocks’, Engineering, Technology & Applied Science Research, vol. 10, no. 3, Art. no. 3, Jun. 2020, doi: 10.48084/etasr.3502.
- [10] M. Doğan and A. Günaydın, “Pounding Of Adjacent RC Buildings During Seismic Loads”, ESOGÜ Müh Mim Fak Derg, vol. 22, no. 1, pp. 129–145, 2009.

# Webography

[5] 'Full article: Effects of pounding on adjacent buildings of varying heights during earthquake in Pakistan'. Accessed: Jun. 12, 2024. [Online]. Available: <https://www.tandfonline.com/doi/full/10.1080/23311916.2016.1225878>

# Courses

[11] Mr. BOURZAM, Bâtiment-1- Calculs Elémentaires des Structures, ENP, 2023/2024.

[12] Mme. BAOUCHE, Cours Structure en Béton Armé, ENP, 2023/2024.

[13] Mme. CHERRAK, Cours de Béton Armé, ENP, 2022/2023.

[14] Mr. TADJADIT, calcul des structures assistes par ordinateur, ENP, 2022/2023.

[15] Mr. TADJADIT, Méthodes des éléments finies, ENP, 2023/2024.

[16] Mr. BOURAHLA, Dynamique des structures, ENP, 2023/2024.

# Software

[13] ETABS software

[14] AutoCad

# Appendices

## Appendix A

### Simple bending diagram

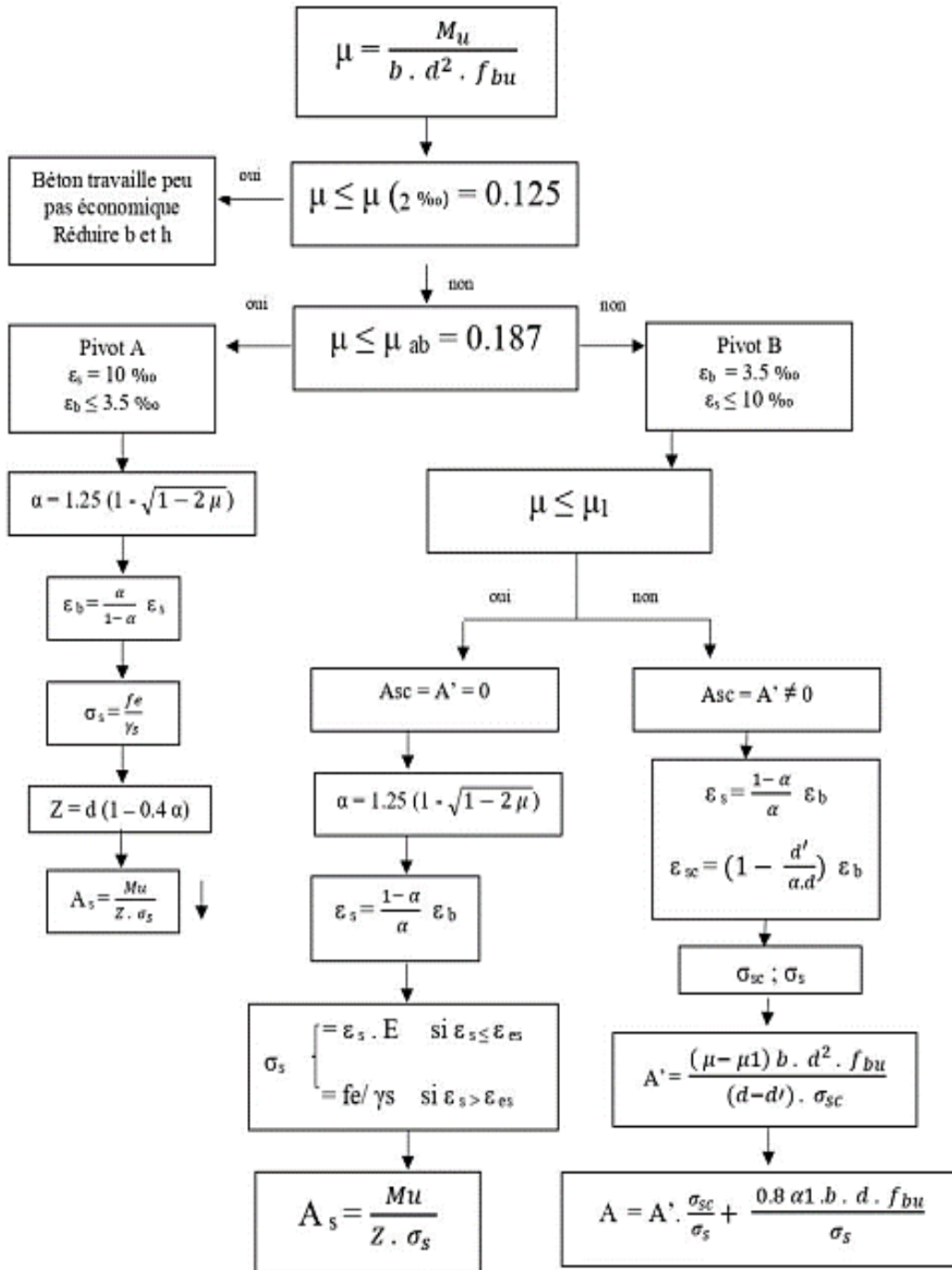

## Appendix B

### Composite bending diagram

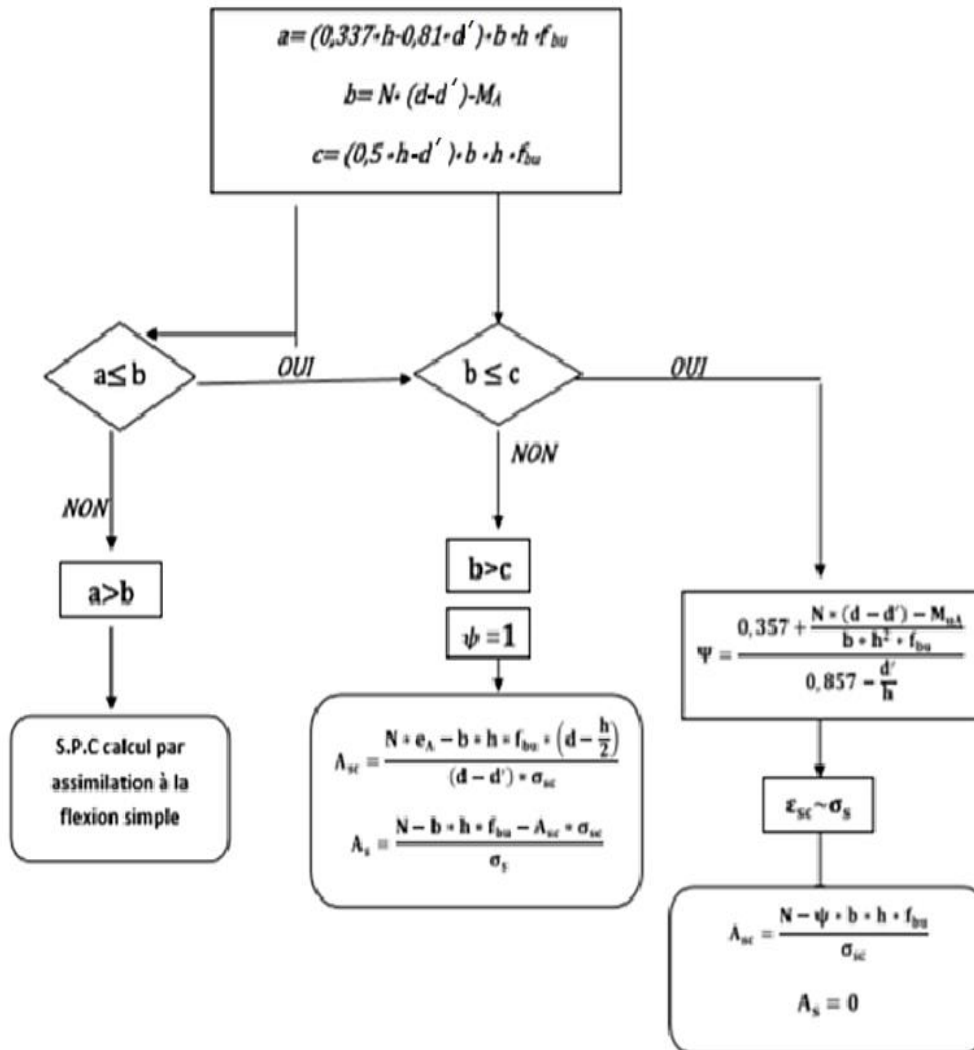



## Appendix C BARES table

Table 1.35

$\mu = 0,15$

$\gamma = \frac{a}{b}$

$M_{x1a} = -\mu M_{as}$

$M_{x0s} = M_{xbs} = \mu M_{yos}$

$M_{x0a} = M_{xbs} = \mu M_{yos}$

$M_{y0s} = \mu M_{xos}$

$\gamma$	$w_1$	$w_{bs}$	$M_{xx}$	$M_{xos}$	$M_{ys}$	$M_{yas}$	$M_{yos}$	$M_{yos}$
0,3	0,3764	0,9700	-0,0489	-0,3833	0,0019	0,0078	-0,0131	-0,033
0,4	0,2565	0,5909	-0,0025	-0,2783	0,0068	0,0173	-0,0242	-0,054
0,5	0,1613	0,3433	0,0132	-0,2004	0,0120	0,0268	-0,0335	-0,070
0,6	0,1031	0,1981	0,0192	-0,1476	0,0177	0,0333	-0,0416	-0,079
0,7	0,0674	0,1211	0,0190	-0,1106	0,0217	0,0384	-0,0493	-0,083
0,8	0,0452	0,0753	0,0173	-0,0865	0,0247	0,0413	-0,0561	-0,084
0,9	0,0315	0,0484	0,0154	-0,0691	0,0270	0,0426	-0,0616	-0,085
1,0	0,0226	0,0324	0,0125	-0,0559	0,0288	0,0435	-0,0664	-0,085
1,2	0,0124	0,0159	0,0086	-0,0387	0,0327	0,0443	-0,0734	-0,084
1,5	0,0055	0,0066	0,0047	-0,0248	0,0370	0,0449	-0,0793	-0,084
2,0	0,0018	0,0021	0,0021	-0,0139	0,0406	0,0450	-0,0830	-0,084
F. m.	$\frac{qa^4}{Eh^3}$	$\frac{qa^4}{Eh^3}$	$qa^2$	$qa^2$	$qb^2$	$qb^2$	$qb^2$	$qb^2$

**Appendix D**  
**Table of steels**

	1	2	3	4	5	6	7	8	9
HA 6	0,28	0,57	0,85	1,13	1,41	1,70	1,98	2,26	2,54
HA 8	0,50	1,01	1,51	2,01	2,51	3,02	3,52	4,02	4,52
HA 10	0,79	1,57	2,36	3,14	3,93	4,71	5,50	6,28	7,07
HA 12	1,13	2,26	3,39	4,52	5,65	6,79	7,92	9,05	10,18
HA 14	1,54	3,08	4,62	6,16	7,70	9,24	10,78	12,32	13,85
HA 16	2,01	4,02	6,03	8,04	10,05	12,06	14,07	16,08	18,10
HA 20	3,14	6,28	9,42	12,57	15,71	18,85	21,99	25,13	28,27
HA 25	4,91	9,82	14,73	19,63	24,54	29,45	34,36	39,27	44,18
HA 32	8,04	16,08	24,13	32,17	40,21	48,25	56,30	64,34	72,38
HA 40	12,57	25,13	37,70	50,27	62,83	75,40	87,96	100,53	113,10