

République Algérienne Démocratique et Populaire
Ministère de l'Enseignement Supérieur et de la Recherche Scientifique
ECOLE NATIONALE POLYTECHNIQUE



DÉPARTEMENT D'ÉLECTRONIQUE

Mémoire de Master

Thème :

Combining techniques

Encadré par :

Pr. AKSAS Rabia

Réalisé par :

Mlle FENNI Sofia

Promotion : Juin 2015

ملخص

تمت دراسة تقنيات دمج الاشارة، تم أيضا شرح مبدئها و تقييم الأداء من حيث متوسط ناتج نسبة الاشارة على التشويش، استخدمت محاكاة باستعمال ماتلاب أيضا للتحقق من أداء كل تقنية ومقارنتها في وقت لاحق

الكلمات المفتاحية: تقنيات دمج الاشارة، تنوع الهوائيات، تقييم الأداء.

Résumé

Les techniques de combinaison ont été étudiées, le principe est expliqué et les performances sont évaluées en terme de SNR moyenne en sortie. Des simulations Matlab ont été utilisé également pour vérifier les performances de chaque technique et les comparer par la suite.

Les mots clé : méthodes de combinaison, diversité, performances.

Abstract

Combining techniques have been studied, the principle is explained and the performances are evaluated in terms of improvement in the average output SNR. Matlab simulations were also used to verify the performance of each technique and compare them thereafter.

Key words: Combining techniques, diversity, performance

Dedication

To my family, to all my teachers and professors since childhood, to my friends and colleagues, and to all those I love.

Acknowledgments

I thank god for all gifts he is giving me including helping me to accomplish this work.

I would like to thank my mentor Professor ***Mr.Aksas*** that guided us with patience during the realization of this work. His advices were very useful to us, especially for writing this thesis.

I want to thank the whole team of the electronics department, more particularly, my dear professors for the efforts they have made for us.

I take this opportunity to thank enormously my teacher ***Mr.Belouchrani*** that has kept encouraging me especially during the 5th year, and for his generosity in terms of training or advices that he brought us during this period.

I associate with these thanks, everyone has contributed to my background since i was young.

Contents

Introduction	6
1 Combining techniques	7
1.1 Introduction	7
1.2 The model	8
1.3 Figures of Merit	8
1.4 Selection Combining	9
1.5 Maximum Ratio Combining	10
1.6 Equal Gain Combining	13
2 Comparison of the Three Techniques	14
Conclusion	18
References	19
Annex	20

List of abbreviations

SIMO	Single Input Multiple Output.
SNR	Signal to Noise Ratio.
BER	Bit Error Rate.
DG	Diversity Gain.
EGC	Equal Gain Combining.
MRC	Maximum Ratio Combining.
SC	Selection Combining.

List of Figures

1.1	The receiver in a diversity combining system [1]	7
1.2	Selection Combining technique [2].	9
1.3	performance of Selection Combining [2].	10
1.4	MRC technique [2]	11
1.5	Performance of a maximal ratio combining system [2]	12
1.6	EGC technique [2]	13
2.1	the improvement in SNR for selection technique [1]	16
2.2	the improvement in SNR for MRC technique [1]	16
2.3	the improvement in SNR for EGC technique [1]	17
2.4	the improvement in SNR for selection technique [1]	17

Introduction

The central idea in diversity is that different antennas receive different versions of the same signal. The chances of all these copies being in a deep fade is small. These schemes therefore make most sense when the fading is independent from element to element. Independent fading would arise in a dense urban environment where the several multipath components add up very differently at each element.

The fading has two main components: large scale fading which is the result of signal attenuation due to signal propagation over large distances and diffraction around large objects in the propagation path, and the second one is small scale fading which is characterized by the rapid amplitude fluctuations of signal and frequency variations such as Doppler effect, generally caused by the impact of multipath that we are dealing with. Diversity combining is therefore specifically targeted to counteract small scale fading which often use Rayleigh fading as a model for the signal fluctuation. It must be emphasized that the Rayleigh model is the easiest and most tractable.

The physical model assumes the fading to be independent from one element to the next. Each element, therefore, acts as an independent sample of the random fading process (here Rayleigh), i.e., each element of the array receives an independent copy of the transmitted signal. Our goal here is to combine these independent samples to achieve the desired goal of increasing the SNR and reducing the BER (Bit Error Rate). Because the N elements in the receiving antenna array, we will receive N independent copies of the same signal. It is unlikely that all N elements are in a deep fade simultaneously. If at least one copy has reasonable power, we will be able to adequately process the signal.

We will try here to study the three combining techniques: Maximum Ratio Combining (MRC), Equal Gain Combining (EGC) and Selection Combining (SC), and show the performances of each technique using some Matlab simulations, and then make a simple comparison between them.

Chapter 1

Combining techniques

1.1 Introduction

Within diversity combining are three common techniques: Selection Combining, Maximal Ratio Combining (MRC) and Equal Gain Combining (EGC). For all three, the goal is to find a set of weights \mathbf{w} , as shown in Fig 1. The three techniques differ in how this weight vector is chosen. we assume that the receiver has the required knowledge of the channel fading vector h .

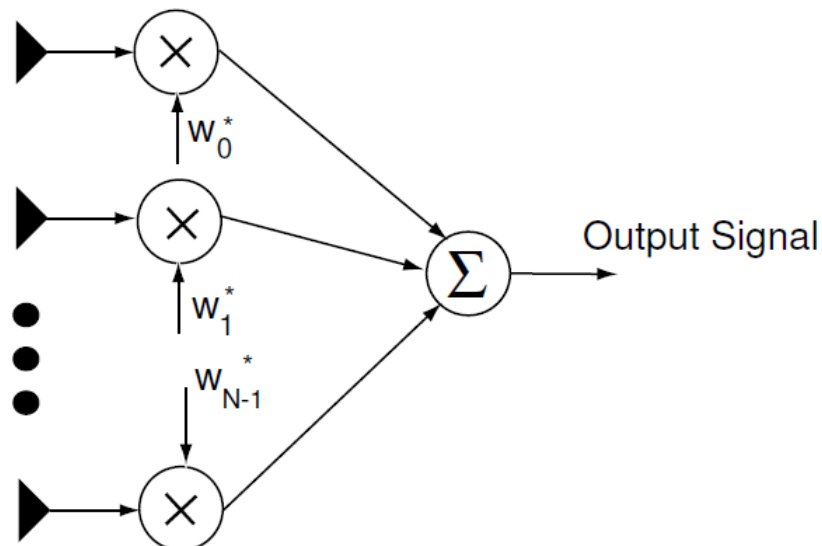

Figure 1.1: The receiver in a diversity combining system [1]

In this chapter we will identify the weight \mathbf{w} for each technique, and then the performance of them in term of **the outage probability**. A comparison between these techniques in term of **the average output SNR** will be made in the next chapter. The concept of **the outage probability** and **the average output SNR** will be described in the section "figure of merit". But before that we should first assume a model to follow.

1.2 The model

We assume a linear model where the received signal is a sum of the desired signal and noise:

$$x = \mathbf{h}u(t) + \mathbf{n} \quad (1.1)$$

where $u(t)$ is the unit power signal transmitted, \mathbf{h} represents the channel (including the signal power) and \mathbf{n} the noise.

The power in the signal over a single symbol period, T_s , at element n , is:

$$P = \frac{1}{T_s} \int_n^{T_s} |h_n(t)|^2 |u(t)|^2 dt = |h_n(t)|^2 \frac{1}{T_s} \int_n^{T_s} |u(t)|^2 dt = |h_n|^2 \quad (1.2)$$

$u(t)$ is assumed to have unit power.

Setting $E\{|h_n(t)|\}^2 = \sigma^2$ and we get the instantaneous SNR at the n -th element

$$\gamma_n = \frac{|h_n|^2}{\sigma^2} \quad (1.3)$$

We are assuming Rayleigh fading, so $h_n = |h_n| e^{j\angle h_n}$, where $\angle h_n$ is uniform in $[0, 2\pi]$ and $|h_n|$ has a Rayleigh pdf, implying $|h_n|^2$ (and so γ_n) has an exponential pdf [2].

$$|h_n| \sim \frac{2|h_n|}{P_0} e^{-|h_n|^2/P_0} \quad (1.4)$$

$$\gamma_n \sim \frac{1}{\Gamma} e^{-\gamma_n/\Gamma} \quad (1.5)$$

$$\Gamma = E\{\gamma_n\} = \frac{E\{|h_n|^2\}}{\sigma^2} = \frac{P_0}{\sigma^2} \quad (1.6)$$

Γ represents the average SNR at each element.

1.3 Figures of Merit

We will use two figures of merit: the outage probability and the average output SNR of the system.

The outage probability is defined as the probability that the output SNR, is below a threshold γ_s .

$$P_{out} = P(\gamma < \gamma_s) = [1 - e^{-\gamma_s/\Gamma}] \quad (1.7)$$

The average SNR of the system given an average SNR Γ of an element, is given by,

$$E\{\gamma\} = \int_0^{\infty} \gamma f_{\Gamma}(\gamma) d\gamma \quad (1.8)$$

where

$$f_{\Gamma}(\gamma) = \frac{P_{out}(\gamma)}{d\gamma}$$

1.4 Selection Combining

The element with the greatest SNR is chosen for further processing. In selection combining therefore,

$$w_k = \left\{ \begin{array}{ll} 1 & \gamma_k = \max \{ \gamma_n \} \\ 0 & \text{otherwise} \end{array} \right\} \quad (1.9)$$

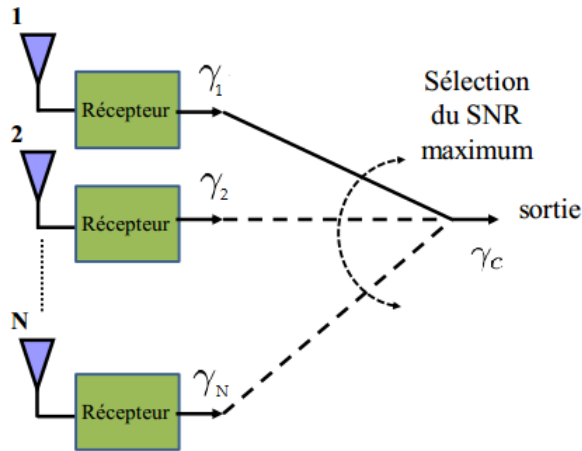

Figure 1.2: Selection Combining technique [2].

$$\gamma_c = \max \{ \gamma_n \} \quad (1.10)$$

Such a scheme would need only a measurement of signal power. Phase shifters or variable gains are not required. To analyze such a system we look at the probability of outage, Therefore

$$P_{out} = P[\gamma < \gamma_s] = P[\gamma_1, \gamma_2, \gamma_3, \dots, \gamma_N < \gamma_s] = \prod_{n=1}^{N-1} P[\gamma_n < \gamma_s] \quad (1.11)$$

The final product expression is valid because the fading at each element is assumed independent. Using the pdf of γ_n ,

$$P_{out} = [1 - e^{-\gamma_s/\Gamma}]^N \quad (1.12)$$

The outage probability therefore decreases exponentially with the number of elements. Figure 1.3 illustrates the improvement in outage probability as a function of the number of elements. As is clearly seen, selecting between just two elements results in significant performance improvements, almost 10dB at an outage probability of 1%. Note that if using two elements the output SNR can, at best, double [1].

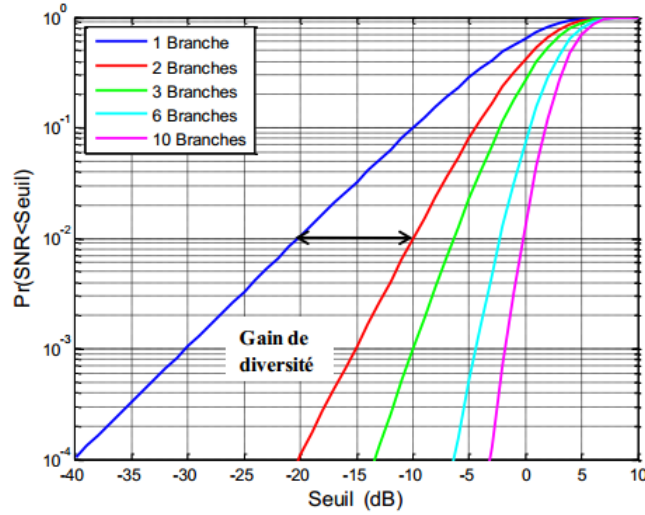

Figure 1.3: performance of Selection Combining [2].

1.5 Maximum Ratio Combining

In the above formulation of selection diversity, we chose the element with the best SNR. This is clearly not the optimal solution as fully $(N-1)$ elements of the array are ignored. Maximal Ratio Combining (MRC) obtains the weights (see Fig 1.1) that maximizes the output SNR, i.e., it is optimal in terms of SNR.

$$\mathbf{x}(t) = \mathbf{h}u(t) + \mathbf{n} \quad (1.13)$$

$$\mathbf{h} = [h_0, h_1, \dots, h_{N-1}]^T \quad (1.14)$$

$$\mathbf{n} = [n_0, n_1, \dots, n_{N-1}]^T \quad (1.15)$$

$$r(t) = w^H \mathbf{x} = w^H \mathbf{h}u(t) + w^H \mathbf{n} \quad (1.16)$$

Since the signal $u(t)$ has unit average power, the instantaneous output SNR is

$$\gamma = \frac{|w^H \mathbf{h}|^2}{E \{|w^H \mathbf{n}|^2\}} \quad (1.17)$$

The noise power in the denominator is given by

$$P_n = E \{|w^H \mathbf{n}|^2\} = E \{|w^H \mathbf{n} \mathbf{n}^H w\}| = w^H E \{\mathbf{n} \mathbf{n}^H\} w = \sigma^2 w^H I_N w \quad (1.18)$$

$$= \sigma^2 w^H w = \sigma^2 \|w\|^2$$

where I_N represents an $N \times N$ identity matrix. Since constants do not matter, one could always scale w such that $\|w\| = 1$. The SNR is therefore given by $\gamma = |w^H \mathbf{h}|^2 / \sigma^2$.

This has a maximum when w is linearly proportional to \mathbf{h} , i.e.,

$$w = \mathbf{h} \quad (1.19)$$

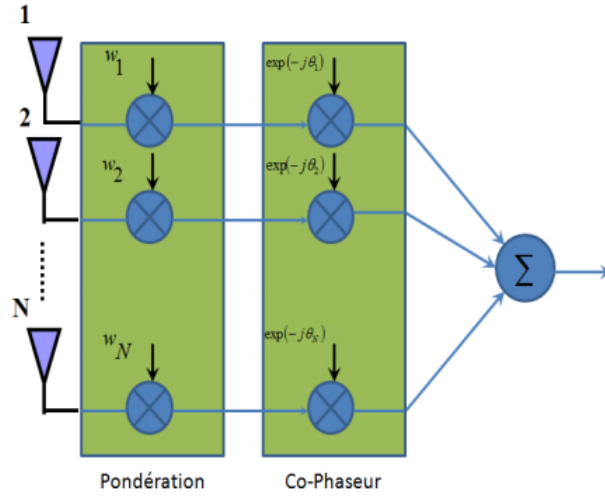

Figure 1.4: MRC technique [2]

the vector w in figure 1.4 is then equal to \mathbf{h}

To determine the outage probability we need to determine the pdf of the output SNR. We use fact that the pdf of the sum of N independent random variables is the convolution of the individual pdfs. Further, the convolution of two functions is equivalent to multiplying the two functions in the frequency (or Laplace) domain. We know that each γ_n is exponentially distributed. The characteristic function of a random variable X is given by $E \{e^{-sX}\}$, i.e., the characteristic function is the Laplace transform of the pdf.

$$F_{\Gamma_n}(s) = E \{e^{-s\gamma_n}\} = \frac{1}{1 + s\Gamma}. \quad (1.20)$$

$$F_{\Gamma}(s) = \left[\frac{1}{1 + s\Gamma} \right]^N, \quad (1.21)$$

$$\Rightarrow PDF(\Gamma) = f_{\Gamma}(s) = L^{-1}[F_{\Gamma}(s)] = \frac{1}{2\pi j} \int_{c-j\infty}^{c+j\infty} \frac{e^{s\gamma}}{(1 + s\Gamma)^N} d\gamma, \quad (1.22)$$

$$= \frac{1}{(N-1)!} \frac{\gamma^{N-1}}{\Gamma^N} e^{-\gamma/\Gamma} \quad (1.23)$$

where L^{-1} denotes the inverse Laplace transform.

Using this pdf, the outage probability for a threshold γ_s is

$$\begin{aligned} P_{out} &= P(\gamma < \gamma_s) = \int_0^{\gamma_s} \frac{1}{(N-1)!} \frac{\gamma^{N-1}}{\Gamma^N} e^{-\gamma/\Gamma} d\gamma, \\ &= 1 - e^{-\gamma_s/\Gamma} \sum_{n=0}^{N-1} \left(\frac{\gamma_s}{\Gamma} \right)^n \frac{1}{n!} \end{aligned} \quad (1.24)$$

Figure 1.5 illustrates the performance of a MRC with multiple antenna elements. Again, the large performance gains from using two or more elements is clear. At a outage probability of 1we achieve a diversity gain (DG) of greater than 11dB.

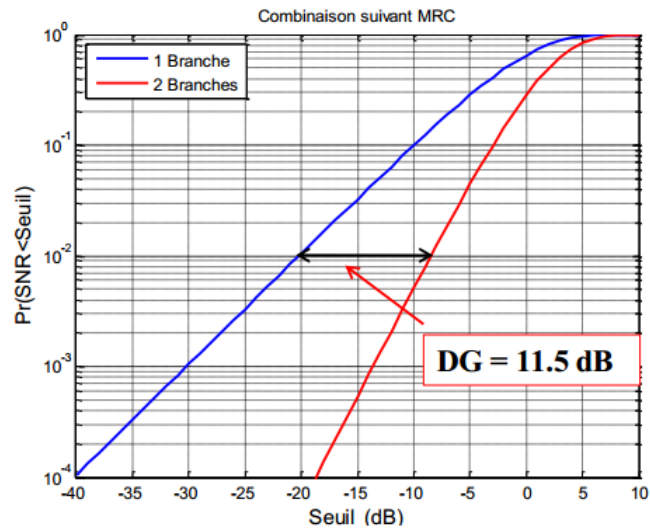

Figure 1.5: Performance of a maximal ratio combining system [2]

1.6 Equal Gain Combining

we developed the combiner that is optimal in the sense of SNR. However, the technique requires the weights to vary with the fading signals, the magnitude of which may fluctuate over several 10s of dB. The equal gain combiner sidesteps this problem by setting unit gain at each element. In the equal gain combiner

$$w_n = e^{j\angle h_n} \quad (1.25)$$

$$\implies w_n^* h = |h_n|. \quad (1.26)$$

$$\implies w^H h = \sum_{n=0}^{N-1} |h_n|. \quad (1.27)$$

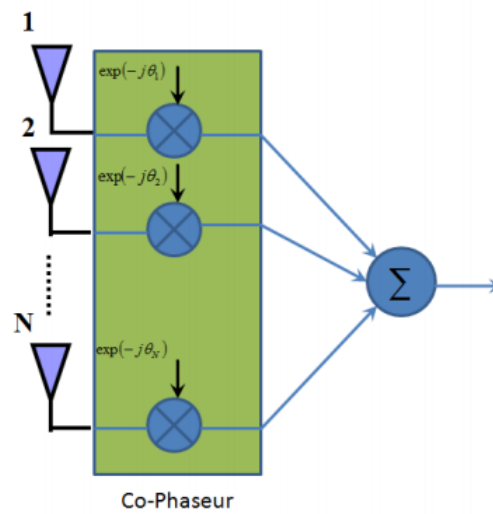

Figure 1.6: EGC technique [2]

Chapter 2

Comparison of the Three Techniques

We compare the performance of the three techniques in terms of the complexity and improvement in output average SNR using Matlab simulation results.

For the selection technique, the resulted average SNR of the diversity system of N element is given by,

$$E\{\gamma\} \simeq \Gamma\left(C + \ln N + \frac{1}{2N}\right) \quad (2.1)$$

The improvement in SNR over that of a single element is of order of $(\ln N)$

For MRC technique using the previous equations of MRC section we find the average SNR as follow:

$$\gamma = \frac{|h^H h|^2}{\sigma^2 h^H h} = \frac{h^H h}{\sigma^2} = \sum_{n=0}^{N-1} \frac{|h_n|^2}{\sigma^2} = \sum_{n=0}^{N-1} \gamma_n \quad (2.2)$$

The output combined instantaneous SNR is, therefore, the sum of the instantaneous SNR at each element. The best a diversity combiner can do is to choose the weights to be the fading to each element. In some sense, this answer is expected since the solution is effectively the matched filter for the fading signal.

the expected value of the output average SNR is therefore N times the average SNR at each element,

$$E\{\gamma\} = N\Gamma \quad (2.3)$$

Which indicates that on average, the SNR improves by a factor of N . This is significantly better than the factor of $(\ln N)$ improvement in the selection diversity case.

For EGC technique using the previous equations of EGC section we find the average SNR as follow:

the noise and instantaneous SNR are given by

$$P_n = w^H w \sigma^2 = N\sigma^2 \quad (2.4)$$

$$\gamma = \frac{\left[\sum_{n=0}^{N-1} |h_n| \right]^2}{N\sigma^2} \quad (2.5)$$

Using the fact that $|h_n|$ is Rayleigh distributed, using the pdf of Eqn 1.5

$$E(|h_n|) = \sqrt{\pi P_0} \quad (2.6)$$

$$E(|h_n|^2) = P_0 \quad (2.7)$$

Using the SNR defined in Eqn. (2.5) together with Eqns. (2.6) and (2.7) we find the mean SNR is given by

$$E(\gamma) = \frac{E \left\{ \left[\sum_{n=0}^{N-1} |h_n| \right]^2 \right\}}{2N\sigma^2} \quad (2.8)$$

$$= \left[1 + (N-1) \frac{\pi}{4} \right] \Gamma. \quad (2.9)$$

The point of this analysis is to show that, despite being significantly simpler to implement, the equal gain combiner results in an improvement in SNR that is comparable to that of the optimal maximal ratio combiner. The SNR of both combiners increases linearly with N.

Figures 2.1, 2.2 and 2.3 plots respectively the improvement in SNR as a function of the number of elements for selection technique, MRC technique, EGC technique and figure 2.4 plot the improvement in SNR for the three techniques. As expected the best improvement is for the maximal ratio combiner, while the worst is for the selection diversity technique. Note that the improvement in the case of equal gain combining is comparable to that of maximal ratio combining.

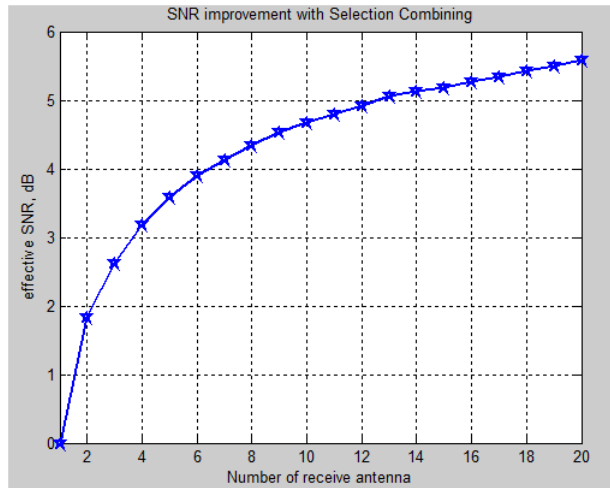

Figure 2.1: the improvement in SNR for selection technique [1]

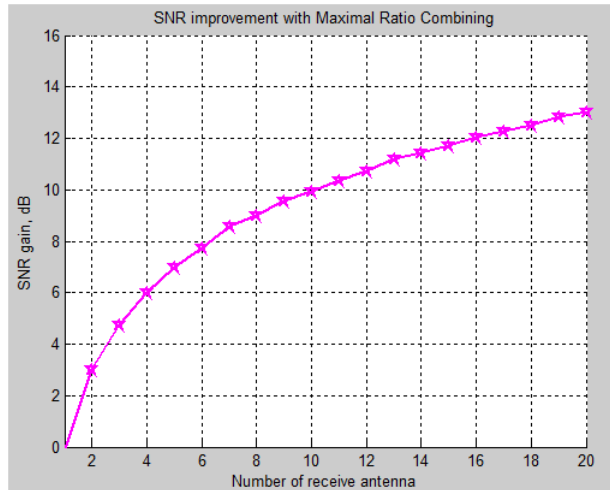

Figure 2.2: the improvement in SNR for MRC technique [1]

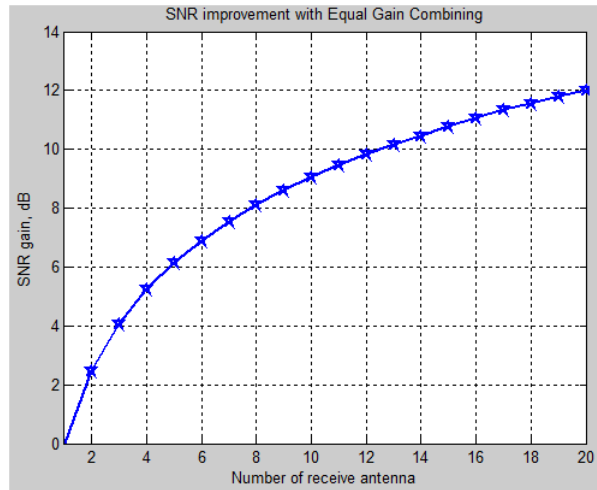

Figure 2.3: the improvement in SNR for EGC technique [1]

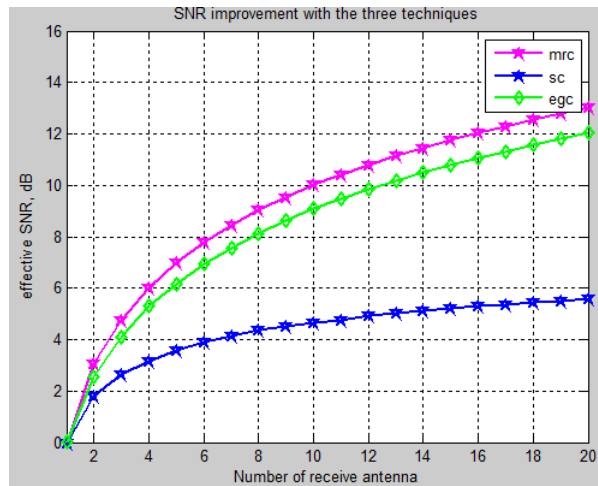

Figure 2.4: the improvement in SNR for selection technique [1]

In terms of the required processing, the selection combiner is the easiest - it requires only a measurement of SNR at each element, not the phase or the amplitude. Both the maximal ratio and equal gain combiners, on the other hand, require phase information. The maximal ratio combiner requires accurate measurement of the gain too. This is clearly difficult to implement, as the dynamic range of a Rayleigh fading signal may be quite large.

Conclusion

we have investigated Selection (the easiest and least optimal), Maximal Ratio (the optimal and most difficult) and Equal Gain (a trade off between the two). Selection combining required no phase shifters or gain elements, only the measurement of SNR at each element. However, the gain in output SNR rose only on order of $\ln N$. MRC required both phase shifters and variable gains at each element. The gain in SNR rose as N . Finally, EGC required only phase shifters while still providing gain in SNR on order of N .

For more perspectives the Hybrid Selection / Maximal Ratio Combining (HS-MRC), or Hybrid Selection/Equal Combining (HS-EGC) that consider hybridization of Selection combining and other combining technique (MRC, EGC) which is done to improve the required signal strength and to reduce the noise factor [3][4], could be a better solution.

References

- [1] A.Chouman, "Synthèse d'un canal de propagation par système multi-antennes pour la caractérisation de terminaux mobiles à diversité", Thèse de Doctorat, Université de Limoges, Juin 2011 .
- [2] Receive diversity, Notes by Prof. Raviraj Adve.
- [3] P.Polydorou, P. Ho, "Asymptotic Analysis of Hybrid Selection / Equal Gain Combining Diversity Receivers", IEEE, 2005.
- [4] P. Sharma, A.S.Buttar, "BER Improvement in Rayleigh Fading SIMO Channel Using Hybrid Diversity Combining Technique", International Journal on Recent and Innovation Trends in Computing and Communication ISSN: 2321-8169 Volume: 2, Issue: 8.

Annex

Code for computing the SNR improvement in Rayleigh fading channel with selection diversity.

```
clear
N = 10^4; % number of bits or symbols

% Transmitter
ip = rand(1,N)>0.5; % generating 0,1 with equal probability
s = 2*ip-1; % BPSK modulation

nRx = [1:20];
Eb_NO_dB = [25]; % multiple Eb/NO values

for jj = 1:length(nRx)
    for ii = 1:length(Eb_NO_dB)

        n = 1/sqrt(2)*[randn(nRx(jj),N) + j*randn(nRx(jj),N)]; % white gaussian noise, 0dB variance
        h = 1/sqrt(2)*[randn(nRx(jj),N) + j*randn(nRx(jj),N)]; % Rayleigh channel

        % Channel and noise Noise addition
        sD = kron(ones(nRx(jj),1),s);
        y = h.*sD + 10^(-Eb_NO_dB(ii)/20)*n;

        % finding the power of the channel on all rx chain
        hPower = h.*conj(h);

        % finding the maximum power
        [hMaxVal ind] = max(hPower,[],1);
        hMaxValMat = kron(ones(nRx(jj),1),hMaxVal);

        % selecting the chain with the maximum power
        ySel = y(hPower==hMaxValMat);
        hSel = h(hPower==hMaxValMat);

        % effective SNR
        EbNOEffSim(ii,jj) = mean(hSel.*conj(hSel));

    end
end

% plot
close all
figure
plot(nRx,10*log10(EbNOEffSim),'bp-','LineWidth',2);
axis([1 20 0 6])
grid on
xlabel('Number of receive antenna');
```

```
ylabel('effective SNR, dB');
title('SNR improvement with Selection Combining');
```

Code for computing the SNR improvement in Rayleigh fading channel with Maximal Ratio Combining.

```
clear
N = 10^3; % number of bits or symbols

% Transmitter
ip = rand(1,N)>0.5; % generating 0,1 with equal probability
s = 2*ip-1; % BPSK modulation

nRx = [1:20];
Eb_NO_dB = [25]; % multiple Eb/NO values

for jj = 1:length(nRx)
    for ii = 1:length(Eb_NO_dB)

        n = 1/sqrt(2)*[randn(nRx(jj),N) + j*randn(nRx(jj),N)]; % white gaussian noise, 0dB variance
        h = 1/sqrt(2)*[randn(nRx(jj),N) + j*randn(nRx(jj),N)]; % Rayleigh channel

        % Channel and noise Noise addition
        sD = kron(ones(nRx(jj),1),s);%sD = 1;
        y = h.*sD + 10^(-Eb_NO_dB(ii)/20)*n;

        % maximal ratio combining
        yHat = sum(conj(h).*y,1);

        % effective SNR
        EbNOEffSim(ii,jj) = mean(abs(yHat));
    end
end

close all
figure
plot(nRx,10*log10(EbNOEffSim),'mp-','LineWidth',2);
axis([1 20 0 16])
grid on
xlabel('Number of receive antenna');
ylabel('SNR gain, dB');
title('SNR improvement with Maximal Ratio Combining');
```

Code for computing the SNR improvement in Rayleigh fading channel with EGC diversity

```
clear
N = 10^4; % number of bits or symbols

% Transmitter
ip = rand(1,N)>0.5; % generating 0,1 with equal probability
s = 2*ip-1; % BPSK modulation
nRx = [1:20];
Eb_NO_dB = [25]; % multiple Eb/NO values

for jj = 1:length(nRx)
    for ii = 1:length(Eb_NO_dB)

        n = 1/sqrt(2)*[randn(nRx(jj),N) + j*randn(nRx(jj),N)]; % white gaussian noise, 0dB variance
        h = 1/sqrt(2)*[randn(nRx(jj),N) + j*randn(nRx(jj),N)]; % Rayleigh channel

        % Channel and noise Noise addition
        sD = kron(ones(nRx(jj),1),s);
        y = h.*sD + 10^(-Eb_NO_dB(ii)/20)*n;

        % equalization with equal gain combining
        yHat = y.*exp(-j*angle(h)); % removing the phase of the channel
        yHat = sum(yHat,1); % adding values from all the receive chains

        % effective SNR
        EbNOEffSim(ii,jj) = mean(yHat.*conj(yHat))/nRx(jj);

    end
end

% plot
close all
figure

plot(nRx,10*log10(EbNOEffSim),'bp-','LineWidth',2);
axis([1 20 0 14])
grid on
xlabel('Number of receive antenna');
ylabel('SNR gain, dB');
title('SNR improvement with Equal Gain Combining');
```

Code for comparing the three techniques

```
clear
N = 10^4; % number of bits or symbols

% Transmitter
ip = rand(1,N)>0.5; % generating 0,1 with equal probability
s = 2*ip-1; % BPSK modulation

nRx = [1:20];
Eb_NO_dB = [25]; % multiple Eb/NO values

for jj = 1:length(nRx)
    for ii = 1:length(Eb_NO_dB)
        n = 1/sqrt(2)*[randn(nRx(jj),N) + j*randn(nRx(jj),N)]; % white gaussian noise, 0dB variance
        h = 1/sqrt(2)*[randn(nRx(jj),N) + j*randn(nRx(jj),N)]; % Rayleigh channel

        % Channel and noise Noise addition
        sD = kron(ones(nRx(jj),1),s);%sD = 1;
        y = h.*sD + 10^(-Eb_NO_dB(ii)/20)*n;

        % maximal ratio combining
        yHat = sum(conj(h).*y,1);
        % effective SNR
        EbNOEff_mrc(ii,jj) = mean(abs(yHat));

        %selection
        % finding the power of the channel on all rx chain
        hPower = h.*conj(h);

        % finding the maximum power
        [hMaxVal ind] = max(hPower,[],1);
        hMaxValMat = kron(ones(nRx(jj),1),hMaxVal);

        % selecting the chain with the maximum power
        ySel = y(hPower==hMaxValMat);
        hSel = h(hPower==hMaxValMat);
        % effective SNR
        EbNOEff_sc(ii,jj) = mean(hSel.*conj(hSel));

        % equalization with equal gain combining
        yHat_e = y.*exp(-j*angle(h)); % removing the phase of the channel
        yHat_e = sum(yHat_e,1); % adding values from all the receive chains

        % effective SNR
        EbNOEff_egc(ii,jj) = mean(yHat_e.*conj(yHat_e))/nRx(jj);
    end
end

% plot
close all
figure
```

```
plot(nRx,10*log10(EbN0Eff_egc),'gd-', 'LineWidth',2);
hold on
plot(nRx,10*log10(EbN0Eff_sc),'bp-', 'LineWidth',2);
hold on
plot(nRx,10*log10(EbN0Eff_mrc),'mp-', 'LineWidth',2);

grid on
legend('mrc' , 'sc', 'egc');
axis([1 20 0 16])
xlabel('Number of receive antenna');
ylabel('effective SNR, dB');
title('SNR improvement with the three techniques');
```